



## Product

**IT1008CP - Intatherm eco thermostatic basin mixer tap with copper tails 7l/min**

**IT1008CP4 - Intatherm eco thermostatic basin mixer tap with copper tails 4l/min**

**IT1008FT - Intatherm eco thermostatic basin mixer tap with flexible tails 7l/min**

**IT1008FT4 - Intatherm eco thermostatic basin mixer tap with flexible tails 4l/min**

## Technical Specification

<b>Max Inlet Pressure (static):</b>	<b>10 Bar</b>
<b>Min Inlet Pressure (dynamic):</b>	<b>0.2 Bar</b>
<b>Max Inlet Temperature:</b>	<b>85°C</b>
<b>Factory Pre-set Temperature:</b>	<b>43°C with max temp stop</b>
<b>Temperature Stability:</b>	<b>+/-2°C</b>
<b>Inlet Connections:</b>	<b>M10 / 1/2" Tails</b>
<b>Min temperature differential to achieve hot or cold failsafe:</b>	<b>10°C</b>
<b>System Installation:</b>	<b>Unvented, Pressurised, Gravity &amp; Combination</b>



## Additional Information

**Long lever to aid users with limited dexterity**

**Thermostatic sequential control**

**Anti-scald fail-safe technology**

**Available with 350mm copper tails or 400mm flexi tails**

**7l/min or 4l/min flow regulator options**

**Self draining spout**

**WRAS & TMV3 Approved**

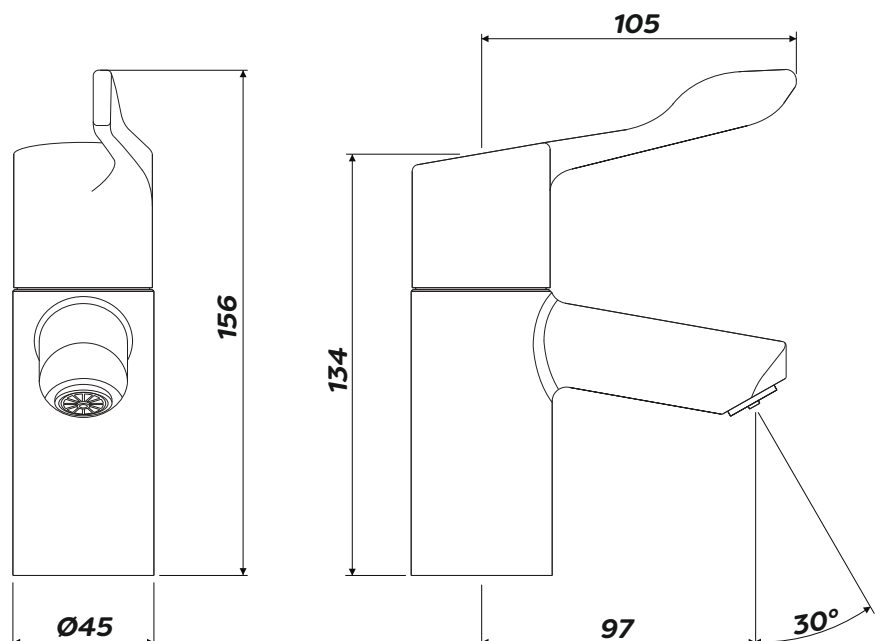

Scan For Spares Sheet

Scan for Installation & Maintenance Instructions

**Intatec, Airfield Industrial Estate, Hixon, Stafford, ST18 0PF**  
**T. 01889 272180 E. sales@intatec.co.uk www.intatec.co.uk**