



## Product

- Z1-11E0000500 - 5L Hydro-Plus Potable Wall Mounted Expansion Vessel
- Z1-11E0000800 - 8L Hydro-Plus Potable Wall Mounted Expansion Vessel
- Z1-11E0001200 - 12L Hydro-Plus Potable Wall Mounted Expansion Vessel
- Z1-11E0001800 - 18L Hydro-Plus Potable Wall Mounted Expansion Vessel
- Z1-11E0002400 - 24L Hydro-Plus Potable Wall Mounted Expansion Vessel

## Technical Specification

<b>Operating Temperatures:</b>	<b>-10°C - 99°C</b>
<b>Max Working Pressure:</b>	<b>10 Bar</b>
<b>Pre Charge Pressure:</b>	<b>2 Bar</b>
<b>Shell:</b>	<b>MIG Welded Carbon</b>
<b>Connection:</b>	<b>Steel Stainless Steel</b>
<b>Membrane:</b>	<b>Butyl</b>

## Dimensions

Part Code	Diameter ØD (mm)	Height H (mm)	Connection ØC (BSP)
Z1-11E0000500	160	270	3/4" G
Z1-11E0000800	200	280	3/4" G
Z1-11E0001200	270	264	3/4" G
Z1-11E0001800	270	349	3/4" G
Z1-11E0002400	300	392	1" G

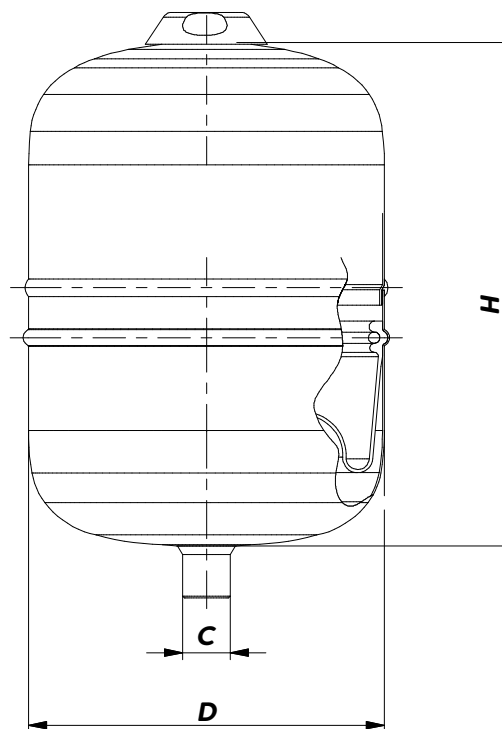

## Additional Information

*Internal polypropylene liner*

*6 years warranty*

*100% factory tested*

*Externally finished in a hard wearing epoxy powder coating*

*Fixed butyl membrane designed to avoid any water stagnation.*

*Fully certified according to the pressure equipment directive 2014/68/EU*

*Scan below for more information and the vessel sizing calculator!*



Scan for Vessel Sizing Calculator