

TRADE-TEC



Product

TRVES08 - TRADE TEC 8LTR HEATING VESSEL C/W BRACKET

TRVES12 - TRADE TEC 12LTR HEATING VESSEL C/W BRACKET

TRVES18 - TRADE TEC 18LTR HEATING VESSEL C/W BRACKET

TRVES25 - TRADE TEC 25LTR HEATING VESSEL C/W BRACKET

TRVES35 - TRADE TEC 35LTR HEATING VESSEL C/W BRACKET

Technical Specification

Max Working Pressure: 4 Bar

Max Working Temperature: 99°C

Pre Charge: 1 Bar

Membrane: Synthetic rubber

Features

Powder coated exterior finish

100% Factory tested

Suitable for multiple types of heating systems

Supplied with mounting bracket

2 years manufacturing warranty

Drawings

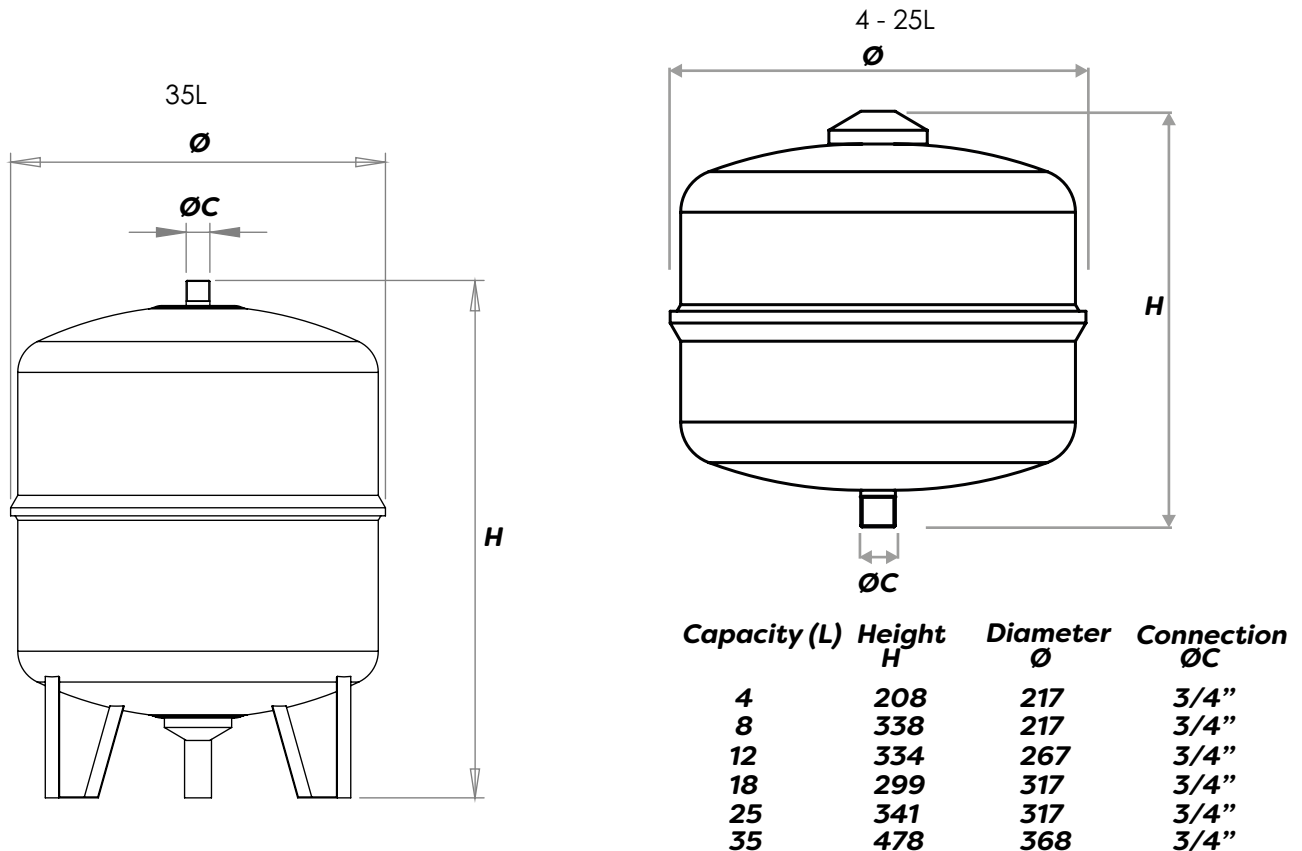

Intatec, Airfield Industrial Estate, Hixon, Stafford, ST18 0PF

T. 01889 272180 F. 01889 272181 E. sales@intatec.co.uk

www.intatec.co.uk

02/2024
E&OE