

TRADE-TEC

Heating Expansion Vessels

TRVES

Installation and Maintenance Instructions

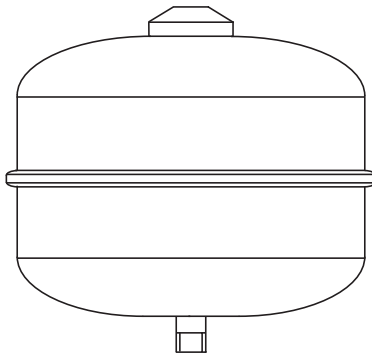

In this procedure document we have endeavoured to make the information as accurate as possible.

We cannot accept any responsibility should it be found that in any respect the information is inaccurate or incomplete or becomes so as a result of further developments or otherwise.

Intatec Ltd
Airfield Industrial Estate
Hixon
Staffordshire
ST18 0PF

Tel: **01889 272 180**
Fax: **01889 272 181**
email: **sales@intatec.co.uk**
web: **www.intatec.co.uk**

TRADE-TEC

Introduction

This installation guide has been produced for the Trade-Tec TRVES series expansion vessels for heating services. These instructions cover the installation, operation and maintenance. Please read the enclosed instructions before commencing the installation of this product, please note;

We recommend that the installation of any Trade-Tec product is carried out by an approved installer.

This vessel is unsuitable for **POTABLE WATER** and is only suitable for heating services.

Trade-Tec expansion vessels with fixed membrane are manufactured in accordance with the requirements of the 2014/68/EU Pressure Equipment Directive. These instructions have been prepared in accordance with the requirements of article 3.4 of Annex 1 of 2014/68/EU Directive and are enclosed with the product when placed on the market.

The purpose of an expansion vessel is to accommodate the increase in the volume of liquid which occurs during system heating in an unvented circuit.

These expansion vessels incorporate a flexible synthetic diaphragm to prevent contact between the system water or fluid and the sealed air cushion in the tank.

It is recommended, especially in hard water areas, that a water softener such as the ActivFlo or ActivFlo lite be fitted to reduce the risk of calcium deposits forming.

Products

Trade-Tec 8 litre heating expansion vessel c/w bracket	TRVES08
Trade-Tec 12 litre heating expansion vessel c/w bracket	TRVES12
Trade-Tec 18 litre heating expansion vessel c/w bracket	TRVES18
Trade-Tec 24 litre heating expansion vessel c/w bracket	TRVES25
Trade-Tec 35 litre heating expansion vessel floor standing	TRVES35

Technical Specification

Max. working pressure:	4 bar
Pre-charge pressure:	1 bar
Maximum temperature of the system:	90°C
Temperature range of the expansion vessel:	-10°C* to 70°C
Externally powder coated:	rouge red
All expansion vessels are 100% factory tested	

Safety

The technical specification of the expansion vessel are shown on the identification label applied to each vessel including:

- product identification
- expansion vessel volume
- maximum working pressure and temperature
- pre-charge pressure (factory set or user set)
- production year
- serial number

Any use at sustained or instantaneous pressure and temperatures exceeding the prescribed limits is unsafe and can cause reduced expansion vessel life, property damage, serious scalding and/or injuries or death.

* at temperatures **NOT exceeding minus 10°C** the system must contain antifreeze such as ethylene glycol (with a percentage up to 50%)

TRADE-TEC

Dimensions

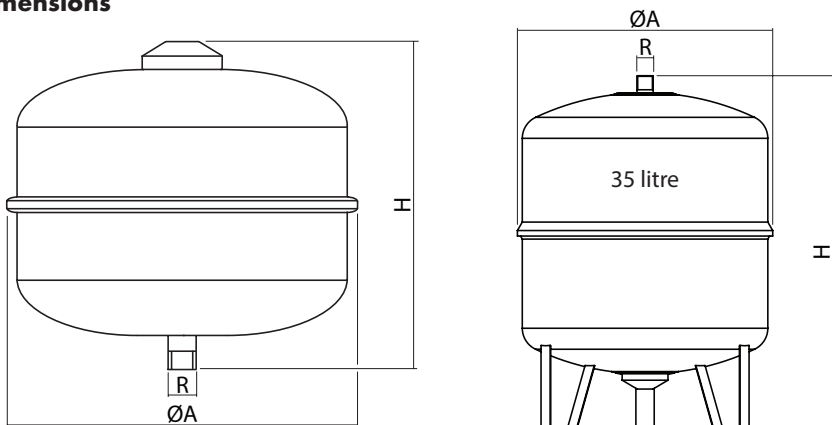

Product Code	Volume	ØA	H	R
TRVES08	8 litre	217	338	G $\frac{3}{4}$
TRVES12	12 litre	267	334	G $\frac{3}{4}$
TRVES18	18litre	317	299	G $\frac{3}{4}$
TRVES25	25 litre	317	341	G $\frac{3}{4}$
TRVES35	35 litre	368	478	G $\frac{3}{4}$

Safety Continued

The expansion vessel may be used in systems having a maximum working temperature of 90 °C providing all means to ensure the temperature on the expansion vessel is 70 °C at maximum (including installation in the coldest part of the system and thermostatic control).

ATTENTION - At the system design stage the correct size of the expansion vessel should be calculated and the correct type of expansion vessel selected according to the system design specification.

The system in which the expansion vessel is to be installed must have a pressure-limiting device such as a pressure relief valve.

Only suitably qualified technicians may perform the calculations and select the choice of the vessel.

Only suitably qualified personnel may install, operate and service this equipment in accordance with this manual and national specifications.

All instructions must be carefully read before installing this expansion vessel.

Expansion vessels are heavy items and should only be transported and lifted into position using the appropriate equipment and all the precautions are adopted when positioning and installing.

The identification label is firmly applied to the expansion vessel and must not be removed, tampered or changed.

If the label on the expansion vessel is missing or the technical characteristics are unreadable, the expansion vessel should not be installed, please contact the technical department at Intatec Ltd.

TRADE-TEC

Installation

To prevent electrolytic or galvanic corrosion the system must be earthed according with local electrical and plumbing codes and standards and, if needed, the expansion vessel may be provided with dielectric joints after evaluating carefully the characteristics of the installation

Other possible causes for pin holing and corrosion phenomena have to be considered, for example water characteristics (including its temperature), presence of oxygen, chemicals and the use of devices made from different materials (e.g. carbon steel and stainless steel, carbon steel and copper).

All of these factors have to be considered by the system designer and by the personnel in charge for the installation.

Means must be provided for preventing air accumulating during normal operation of the system and in the chamber of the expansion vessel (water side).

The expansion vessel and the connected system must be protected against below freezing temperatures, using the correct strength of antifreeze mix or installing the expansion vessel in areas unlikely to freeze.

Do not use this expansion vessel for any other purpose that it has been intended for.

Bacteria can grow in the expansion vessel, especially during times when the system is not in use when the system should be safely disinfected

When installed with the inlet connection upper most a three-way connection on which a pressure gauge and a pressure relief valve may be installed.

Should it be necessary to change the factory pre-charge, only specialised technical personnel should calculate or determine the new pre-charge.

The calculation must ensure that, for all foreseeable working conditions, the specified limits (particularly the maximum working pressure) are never exceeded and local codes and standards are observed.

It is advisable the pre-charge does not exceed 50% of the maximum working pressure and the new value of the pre-charge pressure must be written in the space on the label.

Make sure that the system layout allows for future maintenance and provides sufficient working space around the system to allow for replacement of components whenever necessary.

Disposal of the expansion vessel must be done in an appropriate manner.

If vibration is likely to occur in the vicinity, proper means must be provided in order to insulate the expansion vessel from vibrations (e.g. installation on a resilient mount).

TRADE-TEC

General Instructions for Installation

The 8 to 25 litre expansion vessels are supplied with an integral bracket for wall mounting and the 35 litre expansion vessel is floor standing.

The weight of the expansion vessel filled with water should be supported by the wall bracket. It is important where appropriate that suitable support is given to the adjacent pipework (strapping, hanger, brackets).

Make sure the system is cooled and not pressurised for avoiding scalding and/or serious bodily injuries

Before the installation, remove the plastic cap on the air valve of the expansion vessel and check for the correct factory set pre-charge (with a tolerance of $\pm 20\%$) with a pressure gauge.

Adjust the tank pre-charge to the required value; replace and tighten the plastic cap on the air valve.

After installation and start-up of the system, check for leakage and remove all air from the system.

Check to make sure that the system pressure and temperature are within a safe operating range; if necessary, remove system water to bring the system pressure within safe limits and/or adjust the temperature control up to the desired ending temperature.

Do not over-tighten the threaded connection.

Maintenance

Please note that only qualified personnel may perform service and maintenance.

To perform maintenance and control, make sure the system is off, cooled and not pressurised, all the electric parts are not energised and the expansion vessel is completely empty.

At least once every year the expansion vessel has to be verified, checking that the pre-charge is within the value indicated on the label (factory pre-charge or customer set pre-charge) with a tolerance of $\pm 20\%$, if not otherwise stated.

For a longer life of the expansion tank's external protection, a periodical external cleaning shall be performed using only water and soap.

If a significant drop in the pre-charge pressure may signify that the vessel is nearing the end of its life and may require replacing.

Intatec Ltd shall not be responsible for any damage to property and/or injuries to personnel due to not observing all the above instructions and particularly to improper calculations and selection, installation, operation and maintenance of the tank itself and/or the connected system.

TRADE-TEC

Sizing

The appropriate sizing of an expansion vessel must be undertaken by a qualified engineer.

Temperature	10 °C	20 °C	30 °C	40 °C	50 °C	55 °C	60 °C	65 °C
e Value	0.00025	0.00174	0.00426	0.00782	0.01207	0.01450	0.01704	0.01980
Temperature	70 °C	75 °C	80 °C	85 °C	90 °C	95 °C	100 °C	
e Value	0.02269	0.2580	0.02899	0.03240	0.03590	0.03960	0.04343	

$$V = \frac{e \times C}{1 - P_i/P_f}$$

V = expansion vessel size

e = expansion co-efficient corresponding to the difference between the cold water system temperature and the maximum working pressure

Typical values:

$$e = 0.02269 \text{ (Tmax } 70^\circ\text{C - Tmin = } 10^\circ\text{C)}$$

C = total water capacity of system in litres - C is between 10 and 20 litres for every 1000 kcal/hr of boiler output - 860 kcal/hr = 1 kW

P_i = initial charge pressure - absolute

this pressure must not be less than the minimum head pressure required by the system or the boiler which ever is the greater

P_f = maximum operating pressure - absolute of the safety relief valve, taking into account any difference in height between the vessel and the safety relief valve.

Example

C = 250 litres

P_i = 1.0 bar - 2.0 bar absolute

P_f = 3 bar - 4.0 bar absolute

$$V = \frac{0.02269 \times 200}{1 - 2.0/4.0}$$

V = 9.1 litre

Nearest size with this capacity 12 litres

TRADE-TEC

Typical Application

The expansion vessel must be fitted to the return side of the central heating system and in such a way that at no time can there be an obstruction between the vessel and the system.

The orientation of the expansion vessels water connection should be downwards to avoid risk of sediment ingress or other debris from the system.

Some provision for the prevention of air ingress into the vessel must also be made as this will degrade the vessel very quickly.

Adequate provision for mounting the expansion vessel must be made by the installer and a suitable bracket or other mounting method used.

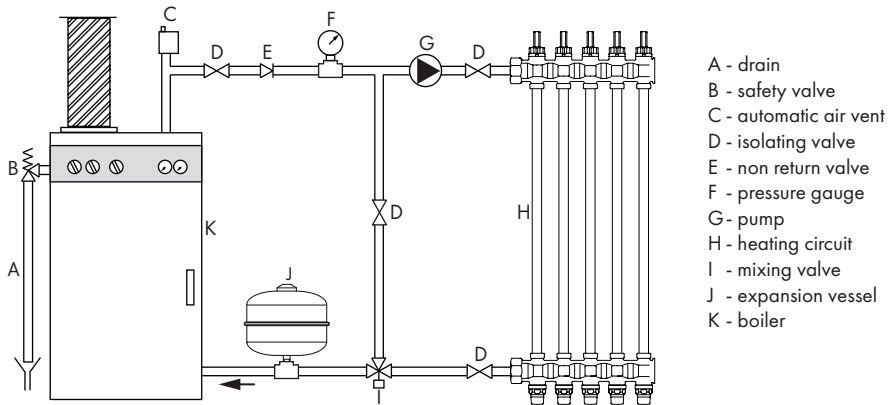

Please pass these instructions to the personnel in charge for installation, operation and service.

TRADE-TEC

Please leave this Manual for the User

To activate your product warranty please visit

www.intatec.co.uk

and click on Product Registration

Intatec Ltd

Airfield Industrial Estate
Hixon
Staffordshire
ST18 0PF

Tel: **01889 272 180**

Fax: **01889 272 181**

email: **sales@intatec.co.uk**

web: **www.intatec.co.uk**

E & O.E