



## Product

HPAFPAK2 - Installer Pack 2

## Contents

Pre-built installer packs, providing everything you need in one convenient package.

- 2x - 1 1/4" F swivel x 1" M flat face extended lever ball valve (HPBV114)
- 1x - 28mm flow balancing valve 5 - 40 L/min with fill & flush (INFBV28)
- 1x - 28mm heat pump filter (IKHPMF28)
- 1x - 28mm auto by-pass valve straight (ABPS28CP)
- 2x - Anti-freeze valves (ZERO28)

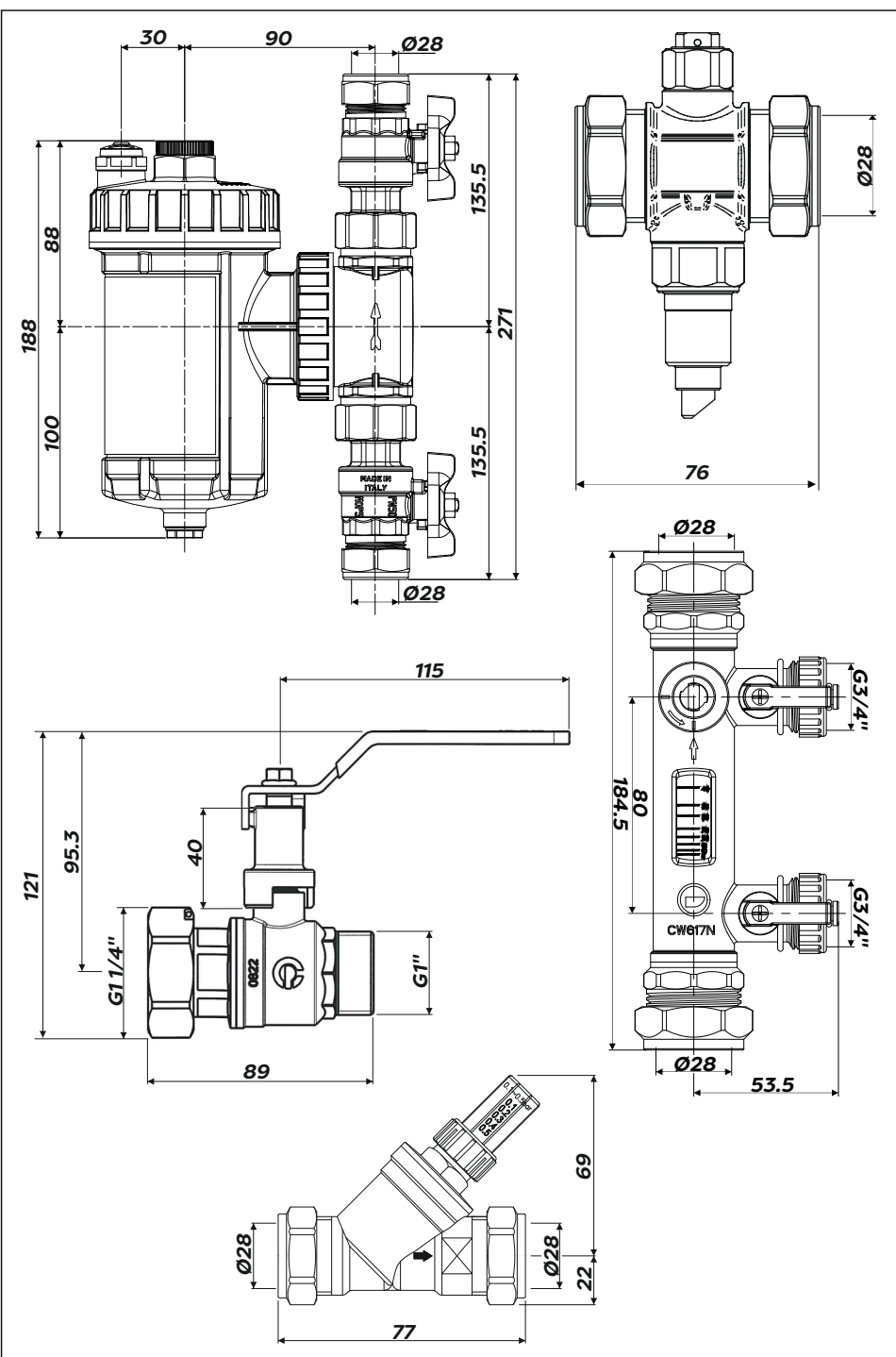

For more information on our heat pump product range please scan:



or visit :  
[www.intatec.co.uk](http://www.intatec.co.uk)