

intamix DELTA

Intamix Thermostatic Mixing Valves DT40015CP & DT40022CP, DT40015MX15CP & DT400MX22CP Installation and Maintenance Instructions

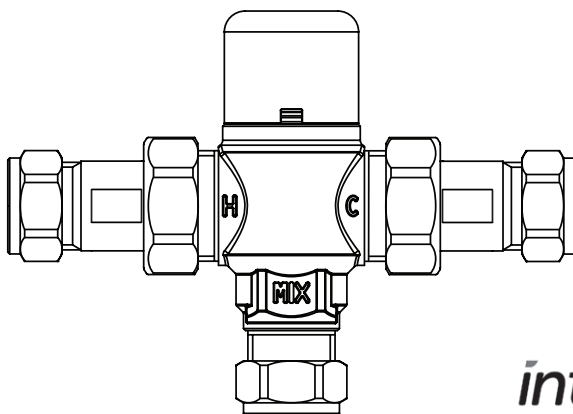

**intamix
DELTA**

Intatec Ltd

Airfield Industrial Estate

Hixon

Staffordshire

ST18 0PF

In this procedure document we have endeavoured to make the information as accurate as possible.

We cannot accept any responsibility should it be found that in any respect the information is inaccurate or incomplete or becomes so as a result of further developments or otherwise.

Tel: **01889 272 180**

Fax: **01889 272 181**

email: **sales@intatec.co.uk**

web: **www.intatec.co.uk**

Intamix Thermostatic Mixing Valves

Product Introduction

The Intamix Delta range of thermostatic mixing valve has been designed and engineered for heat networks where the maximum distribution temperature from the heat interface unit (HIU) is **50°C**.

In these installations standard TMVs that are approved to BS EN 1111: 2017 or BS EN 1287: 2017 may not failsafe when used for bath, shower or wash-hand basin applications. These valves will operate with just **5°C ΔT** between the mixed outlet and the hot inlet.

Our new Intamix Delta range accommodates these lower inlet temperatures whilst providing Intatec's proven anti-scald protection for safety and peace of mind.

It is recommended, especially in hard water areas, that a water softener such as the ActivFlo or ActivFlo lite be fitted to reduce the risk of calcium deposits forming.

Product Range

Description

Intamix Thermostatic Mixing Valve - 15mm

Intamix Thermostatic Mixing Valve - 22mm

Intamix Thermostatic Mixing Valve - 15mm with service valves

Intamix Thermostatic Mixing Valve - 22mm with service valves

Product Code

DT40015CP

DT40022CP

DT400MX15CP

DT400MX22CP

Technical Specification

Maximum Inlet Pressure - Static	10 bar
Minimum Inlet Pressure - Dynamic	0.2 bar
Maximum Inlet Temperature	85°C
Temperature Adjustment Range	30°C to 50°C
Temperature Stability	±2°C
Maximum Differential Pressure	5:1
Minimum Temperature Differential Between Hot Inlet and Mixed Water Outlet to Achieve Cold Water Failsafe	5°C

Dimensions

See Appendix A for dimensions with standard and MX union ends.

Flowrates

See Appendix B for pressure drops and flow chart.

Installation Guide

Application

The thermostatic mixing valve has been tested as meeting the general requirements of the BS EN 1111:2017 and BS EN 1287:2017 as being suitable for use on the following designations.

Application	Range	Application	Range
Basin	High Pressure	Basin	Low Pressure
Bidet	High Pressure	Bidet	Low Pressure
Shower	High Pressure	Shower	Low Pressure
Bath Fill*	High Pressure	*22mm only	

NOTE: Applies to HP installations only. If a water supply is fed by gravity then the supply pressure should be verified to ensure the conditions of use are appropriate for the valve. The installation of thermostatic mixing valves must comply with the requirements of the Water Supply (Water Fittings) Regulations 1999.

Recommended Outlet Temperatures

It is recommended the following set maximum mixed water outlet temperatures are used in all premises:

Application	Recommended Set Mixed Water Temp.
Wash Hand Basin	41°C
Shower	41°C
Bidet	38°C
Bath Fill	44°C

The mixed water temperatures must never exceed 46°C. The maximum mixed water temperature can be 2°C above the recommended maximum set outlet temperatures.

NOTE: 46°C is the maximum mixed water temperature from the bath tap. The maximum temperature takes account of the allowable temperature tolerances inherent in the thermostatic mixing valves and temperature losses in metal baths. It is not a safe bathing temperature for adults or children.

The British Burns Association recommends 37°C to 37.5°C as a comfortable bathing temperature for children. In premises covered by Care Standards Act 2000, the maximum mixed water outlet temperature is 43°C

Installation Guide

Installation

IMPORTANT - The following instructions must be read prior to the installation of the Intamix thermostatic mixing valve. The installer should also be aware of their responsibility and duty of care to ensure that all aspects of the installation comply with all current regulations and legislation.

It has been brought to our attention that flushing through water systems using certain chemicals may wholly or partially remove the lubricant from the internal workings of the valve, which may adversely affect its performance. We recommend that following flushing of the system with chemicals; valves are checked for correct operations.

The installation of thermostatic mixing valves must comply with the requirements of the Water Supply (Water Fittings) Regulations 1999.

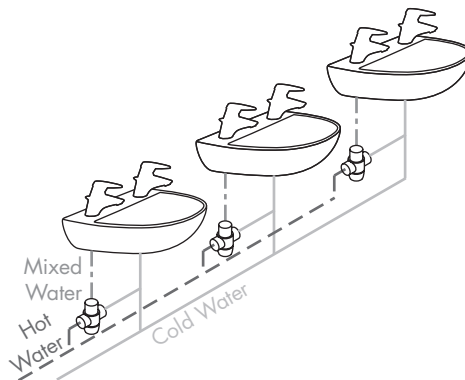

The Inta range of thermostatic mixing valves **MUST** be installed in an accessible position to ensure that maintenance, commissioning and testing of the **Inta Thermostatic Mixing Valves** can be undertaken easily.

- 1 It is essential that before installing any of the Intamix thermostatic mixing valves to ensure that the supply conditions of conditions of the system to which the valves are intended to be fitted are checked to confirm compliance with the parameters as quoted within the Technical Specification and conditions on which the approval is granted i.e. verify supply temperatures, supply pressures, risk assessment.
- 2 Consideration must be made for the possibility of multiple / simultaneous demands being made on the supply system whilst the Inta 15mm and 22mm valves are in use, all practical precautions must be made to ensure that the valves are not affected. Failure to make provision within the pipe sizing etc. will affect the performance of the valves.
- 3 The supply system to which the Inta thermostatic mixing valve is to be installed into must be thoroughly flushed and cleaned to remove any debris, which may have accumulated during the installation. Failure to remove any debris will affect the performance and the manufacturer's warranty of the product Independent filters / check valves and isolation valves must be fitted in conjunction with the valve. In areas that are subject to aggressive water, provision must be made to treat the water supply prior to the supply entering any Inta product.
- 4 The maximum flow rate of the valve will only be achieved when the supply conditions are achieved as quoted within the Technical Specification, with a flow condition under 1 bar differential pressure.

Installation Continued

- 6 We recommend that the Inta fail-safe thermostatic mixing valves be installed as close as practically possible to the outlet, which it is serving. In this situation attention must be paid to the maximum distance of pipe work from the mixed water outlet of the valve to any terminal fitting.
- 7 Current guidelines recommended a maximum distance of 2m from the outlet of any mixing valve to the furthest terminal fitting / outlet to which the mixing valve is to serve.
- 8 The hot and cold water supplies must be connected to the valve strictly in accordance with the indications on the body of the valve i.e. hot water supply to the hot port of the valve.
- 9 In a situation where one or both of the water supplies are excessive, it is possible to fit a pressure reducing valve to reduce the pressure(s) to within the limits as previously quoted.
- 10 Any thermostatic mixing valve must be fitted with a back flow prevention device, such as check valves to prevent the cross contamination of supplies. The Inta valves are complete with integral insert check valves and strainers.
- 11 Y Pattern strainers and full-bore isolation valves must be installed in conjunction with the Inta range of fail-safe thermostatic mixing valves – the Y Pattern Strainers and isolation ball valves must be fitted as close as practically possible to the valve. Alternatively the use of the MX optional tail pieces removes the need for additional filters and isolation valves.
- 12 It is essential that the Inta fail-safe thermostatic mixing valves should not be installed in situations where there is a possibility of the valve being deprived of water or where demands for water are greater than the actual stored supplies.
- 13 To ensure that the performance levels of the Inta thermostatic mixing valves are maintained (in the event of cold water failure), the temperature of the hot water supply at the point of entry to the valves must be a minimum of 10°C above the commissioned mixed water discharge temperature.
- 14 The Inta fail-safe thermostatic mixing valves must not be subject to any extreme temperature variations either during the installation or under normal operating conditions.

Method of Adjusting the Mixed Water Outlet Temperature

IMPORTANT - The following instructions must be read and understood prior to the adjustment of the mixed water outlet temperature and this action **MUST** only be carried out by a suitably qualified person.

- 1 Remove the cap from the valve
- 2 Remove the temperature locking ring from the spindle using a suitably sized spanner
- 3 Open the outlet to which the mixing valve is supplying and establish as stable flow and temperature
4. Using a calibrated thermometer place the sensing part of the thermometer probe under the flowing water
- 5 Using an 8mm Allen key rotate the temperature adjustment spindle anticlockwise to increase the mixed water temperature or clockwise to reduce the mixed water temperature – at all times ensuring the probe of the thermostat is under the flowing water.
- 6 Once the desired temperature is reached – replace the temperature locking ring on the spindle and re fit the cap of the valve.
- 7 **The temperature at the terminal fitting must never exceed 46°C.**

Commissioning

IMPORTANT - The following instructions must be read and understood prior to the commissioning of the Inta range of thermostatic mixing valves. When measuring any mixed water outlet temperature reading, the sensing part of the thermometer probe must be fully submerged in the water. If under any circumstances there are aspects to the installation / system which do not comply with the specification laid down, the valve **MUST NOT** be put into operation until the system / installation complies with our specification. However if all these conditions are met, proceed to set the temperature as follows;

- 1 Ensure the designation of thermostatic mixing valves matches the application and that the system is thoroughly cleaned and free from any debris prior to the commissioning of the Inta range of thermostatic mixing valves. The supply temperatures and pressures are within the valves operating range specified. Providing that all of these conditions are met, please follow the following steps to commission this product.
- 2 The commissioning of the temperatures must be carried out using a suitably calibrated thermometer – preferably a digital thermometer the sensing part of the thermometer probe must be fully submerged in the water when testing.
- 3 Each Valve must be commissioned taking into consideration any fluctuations, which may occur within the system due to simultaneous demands. It is advisable that any outlets which are connected to the same supply as the mixing valve is connected to are open during the setting of the mixed water temperature. During commissioning it is advisable to ensure that the water temperatures are established before any attempt to commission.
- 4 Once the supply temperatures are stable and the normal operating conditions are established, the valve can be commissioned, – the temperature setting can be adjusted by removing the cap and temperature locking ring from the valve body (see section method of adjusting mixed water temperature). We suggest that the following sequence is followed when commissioning the valve;
 - 4.1 Set the mixed water temperature to the required temperature, the temperature at the terminal fitting must never exceed 46°C.
 - 4.2 Measure and record the temperature of the hot and cold water supplies at the connection to the valve.
 - 4.3 Measure and record the temperature of the water discharging from the valve.
 - 4.4 Isolate the cold water supply to the valve and monitor the mixed water temperature.
 - 4.5 Measure and record the maximum mixed water temperature and the final temperature. The final temperature found during the test should not exceed the values quoted
 - 4.6 Record all the equipment used during the commissioning.
 - 4.7 The mixed water temperature at the terminal fitting must never exceed 2°C above set temperature.
 - 4.8 The maximum mixed water supply temperature at the terminal fitting should not exceed 46°C
- 5 Once the desired temperature is established secure the temperature spindle with the locking ring and replace the cap into its original position to prevent tampering by unauthorized persons. Ensure that the application, in which the valve will be used in, is appropriate for the approved designation.
- 6 The above information must be recorded and updated on every occasion when any work is carried out on the valve.

Installation Guide

In-Service Test

The Inta range of thermostatic mixing valves should be tested against the original set temperature results once a year. When commissioning/testing is due the following performance checks shall be carried out. When measuring any mixed water outlet temperature reading the sensing part of the thermometer probe must be fully submerged in the water.

When testing is due the following performance checks shall be carried out;

- 1 Measure the mixed water temperature at the outlet.
- 2 Carry out the cold water supply isolation test by isolating the cold water supply to the TMV, collect the discharge for 5* seconds and record the amount.
- 3 If the valve continues to discharge, collect the discharge for a further 30** seconds and record the amount before restoring the cold water supply.
- 4 Check for any deviation from the initial stable mixed water temperature***.

Acceptance criteria

- * If the volume of water collected is >400ml for bath or >200ml for other outlets then re-check the supply conditions or re-adjust the valve according to this IOM and then re-commission.
 - ** If the volume of water collected is >500ml for bath or >300ml for other outlets then re-check the supply conditions or re-adjust the valve according to this IOM and then re-commission.
 - *** If the deviation is greater than 2°C then service or adjust the valve in line according to this IOM and then re-commission.
- 5 If there is no significant change to the set outlet temperature ($\pm 2^{\circ}\text{C}$ or less change from the original settings) and the fail-safe shut off is functioning, then the valve is working correctly and no further service work is required.
 - 6 If the Inta range of thermostatic mixing valves has been adjusted or serviced it must be re-commissioned and re- tested in accordance with these instructions.

Problem Solving

The following details are supplied for on site queries, should you require any further assistance our Technical Department can be contacted directly on 01889 272199

- 1 **Hot water at the cold tap**
 - i. Operation of the insert check valves is hindered, check the valve is seated correctly.
 - ii. Check Valves not fitted.
 - iii. Unbalanced hot/cold supply pressure.
- 2 **Fluctuating mixed water temperature**
 - i. Erratic supply temperatures at the inlets of the valve.
 - ii. Starvation of the water supplied at the inlets of the valve.
 - iii. Incorrect commissioning of the valve.
- 3 **Erratic flow**
 - i. Insufficient water supplies.
 - ii. Fluctuations in the supply pressures/temperatures.
 - iii. Adverse effect created by other draw off points on the system.

Problem Solving

4 No flow/reduced flow from valve

- i. In line filters are blocked.
- ii. Insufficient supply pressure.
- iii. Debris obstructing valve operation.
- iv. Valve requires servicing (Servicing kits available from your local stockist).

5 Valve does not fail safe when tested

- i. Installation not in accordance with our recommendations.
- ii. The minimum temperature differential not achieved.
- iii. Internal mechanism hindered by debris.

Intamix TMV - Appendix A

Dimensions

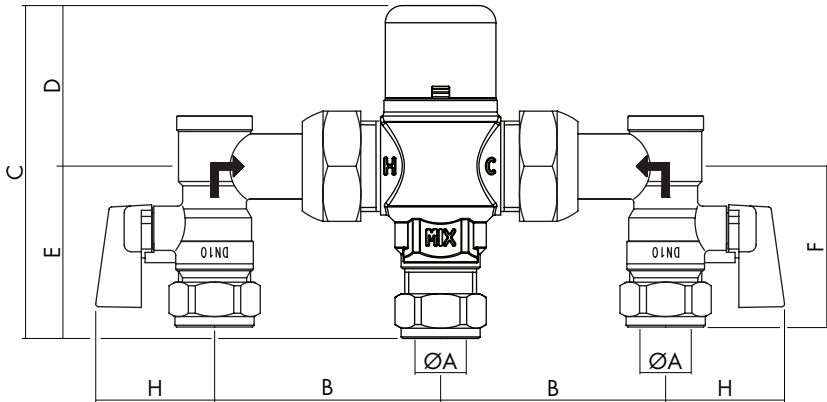
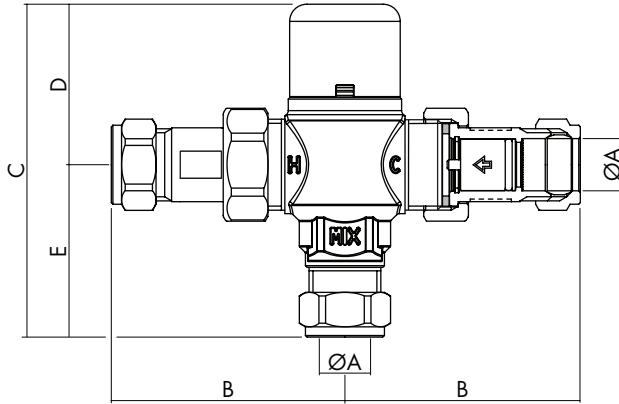

Code	A	B	C	D	E	F	H	kg
DT40015CP	15	70	98	47	51	N/A	N/A	0.5
DT40022CP	22	73	98	47	51	N/A	N/A	0.6
DT400MX15CP	15	63	98	47	51	47	33	0.65
DT400MX22CP	22	64	98	47	51	54	33	0.75

Intamix TMV - Appendix A

Flowrates

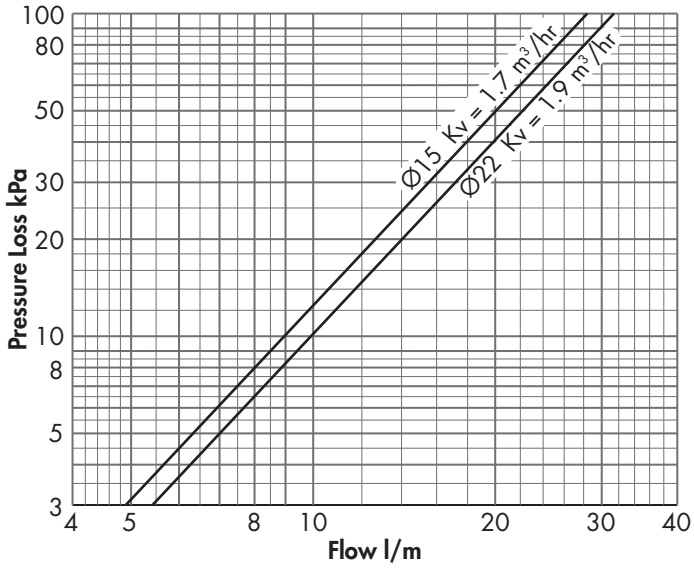

TMV TEST RECORD SHEET

Test Data:

Valve Reference		Location	
Blending Setting	°C	Installation Date	
Outlet Type Bath/wash basin/shower		Test Frequency	
Min. Temp Diff for the valve	°C	Engineer's Name	

Non Compliance with HTM-04-01: Remedial actions required as follows:

COMMISSIONING & IN-SERVICE TEST RESULTS

Test Details	Results	Observation/comments
Hot supply temperature	°C	
Cold supply temperature	°C	
Hot supply pressure	bar	
Cold supply pressure	bar	
Initial stable mixed water temp. at MAX flow	°C	
Temperature differential	°C	
Isolation cold water supply - flow after 5 sec	YES/NO	
TMV2 - Vol. of water collected up to 5 sec*	ml	
TMV2 - Vol. of water collected up to 5 to 35 sec**	ml	
TMV2 - Vol. of water collected at 60 sec***	ml	
Mixed water temp. after supply restored	°C	
Deviation from initial stable mixed water temp****	°C	

- * If the volume of water collected is >400ml for bath or >200ml for other outlets then re-check the supply conditions or re-adjust the valve according to these instructions and re-commission/test.
- ** If the volume of water collected is >500ml for bath or >300ml for other outlets then re-check the supply conditions or re-adjust the valve according to these instructions and re-commission/test.
- *** If the volume of water collected is >120ml re-check the supply conditions or re-adjust the valve according to these instructions and re-commission/test.
- **** If the deviation is greater than 2°C then service or adjust the valve in line with these instructions and then re-commission and re-text

Next In-service Test Date	
---------------------------	--

intamix **DELTA**

Please leave this Manual for the User

To activate your product warranty please visit
www.intatec.co.uk
and click on Product Registration

intamix **DELTA**

Intatec Ltd

Airfield Industrial Estate
Hixon
Staffordshire
ST18 0PF

Tel: **01889 272 180**

Fax: **01889 272 181**

email: **sales@intatec.co.uk**

web: **www.intatec.co.uk**

E & O.E