

inta

Thermostatic Shower Panel

SP9301 CP

Installation and Maintenance Instructions

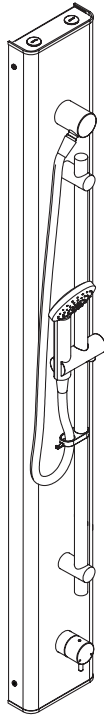

In this procedure document we have endeavoured to make the information as accurate as possible.

We cannot accept any responsibility should it be found that in any respect the information is inaccurate or incomplete or becomes so as a result of further developments or otherwise.

inta

Intatec Ltd

Airfield Industrial Estate

Hixon

Staffordshire

ST18 0PF

Tel: **01889 272 180**

Fax: **01889 272 181**

email: **sales@intatec.co.uk**

web: **www.intatec.co.uk**

Introduction

This installation guide has been produced for the thermostatic shower panel. These instructions cover the installation, operation and maintenance. Please read the enclosed instructions before commencing the installation of this product, please note;

We recommend that the installation of any product is carried out by an approved installer.

The installation must be carried out strictly in accordance with the Water Supply (Water Fitting) Regulations 1999 and any local authority regulations.

If in doubt we recommend that you contact WRAS - Water Regulations Advisory Scheme on Tel: 0333 207 9030, your local water authority - details available on the WRAS website or the Chartered Institute of Plumbing and Heating Engineers on Tel: 01708 472 791.

All products MUST be re-commissioned to suit site conditions to ensure optimum performance levels of the product are obtained.

It is recommended, especially in hard water areas, that a water conditioner such as the ActivFlo be fitted to reduce the risk of calcium deposits forming.

Products

Wall mounted thermostatic shower panel in stainless steel with riser rail,
hand set and hose in chrome finish

SP9301CP

Check Content

Before commencing remove all components from packaging and check each component with the contents list.

Ensure all parts are present, before discarding any packaging. If any parts are missing, do not attempt to install your Inta shower panel until the missing parts have been obtained

Components

Wall plate including thermostatic mixing valve.

Front cover including riser rail, hose retaining ring, handset holder and shower connection.

Flexible hose with ½" swivel connections.

Control knob.

Shower hose.

Handset.

Miscellaneous screws and fittings.

Allen key for security screws

Dimensions

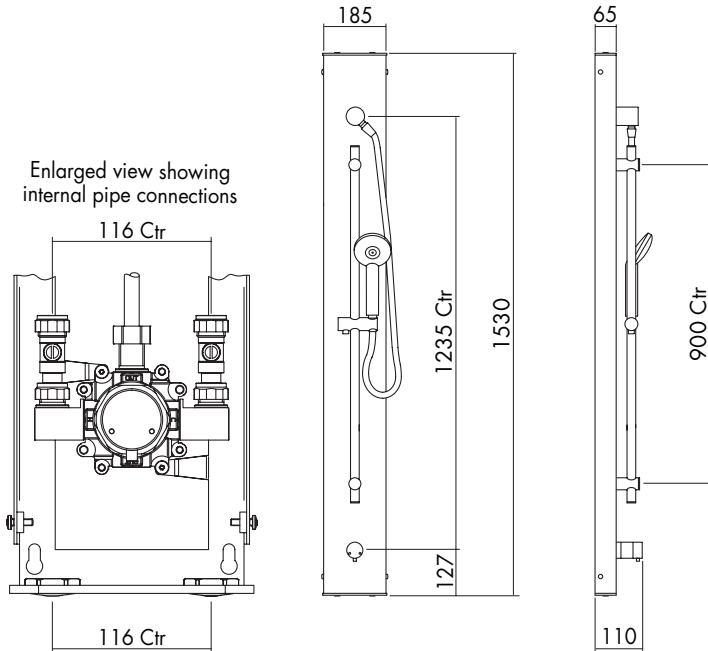

Technical Specification

Maximum pressure:	6 bar
Minimum pressure:	1 bar
Hot water inlet temperature:	50 to 90°C
recommended:	55 to 60°C
Cold water inlet temperature:	5 to 20°C
Minimum temperature differential:	10°C
Outlet water temperature range:	18 to 46°C
Setting tolerance:	±2°C
Factory temperature setting:	41±1°C
Flow rate with flow regulator:	7 l/min

Site Preparation

It is important to plan the installation thoroughly to suit site conditions before commencing.

- Before commencing the installation ensure site conditions are suitable.
- Isolation valves must be fitted in an accessible position to both the hot and cold supplies should the valve need to be isolated in the future for servicing.
- Fitting in-line strainers is recommended as close as is practicable to the water supply inlets of the shower mixing valve.
- The shower panel is intended for mounting on a water proof vertical surface at a height to suit tallest user.
- The supply pipes can come from below, above or through the wall to the panel.
- The wall plate and mixing valve are supplied with pipe connections suitable for the supply pipes to enter from above. Rotating the pipe connections will enable the supply pipes to enter from below.
- Ensure the shower panel will be vertical when installed.
- When installing near a wall ensure there is enough clearance for access to the security screws that secure the front cover. We recommend leaving at least 100mm clearance for the Allen key.
- The whole system should be thoroughly flushed, prior to the connection of the hot and cold water supplies to the shower mixing valve, to remove any debris that may be in the supply pipework.
- Ensure there are no joint leaks before finishing the wall.

Installation

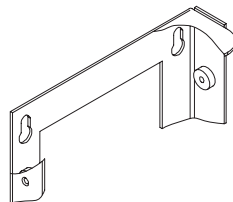

Using the wall plate as a template mark the position of the 4 elongated holes onto the wall ensuring that the wall plate is vertical.

Drill the wall and using suitable wall plugs and screws attach the wall plate and mixing valve firmly to the wall.

Remove the blanking plugs at the top or bottom of the panel to suit the direction of the supply pipes. The elbows containing the compression fittings can be rotated to suit the supply pipes. Connect the supply pipes to the thermostatic mixing valve using the 15mm compression fittings and make water tight joints.

When facing the thermostatic mixing valve the hot water supply should be on the left and the cold on the right.

Attach the flexible hose using a sealing washer to the mixed water outlet of the mixing valve and tighten to make a water tight joint.

Installation Continued

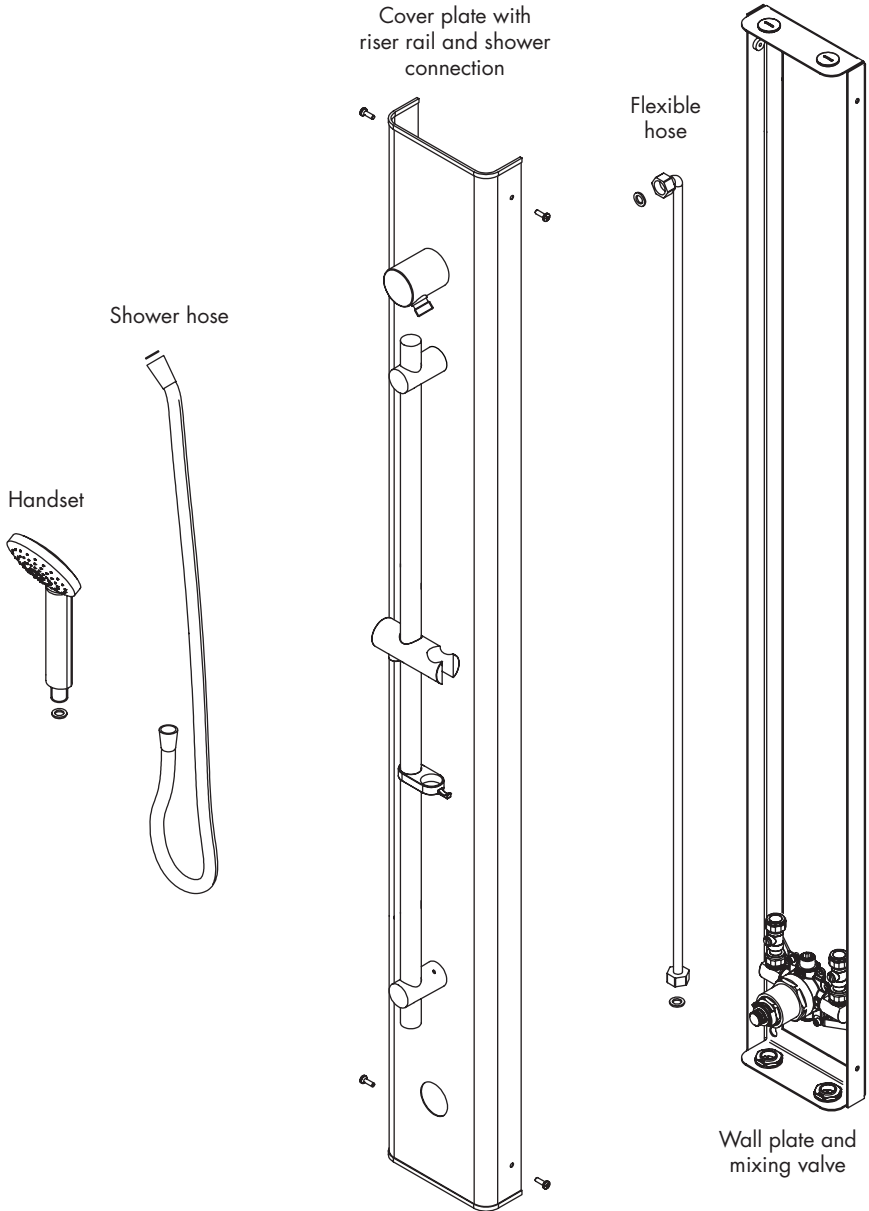

Installation Continued

Attach the flexible hose using a sealing washer to the rear side of the shower connector and tighten to make a water tight joint.

Fit the cover plate to the wall plate and secure in position with the screws provided.

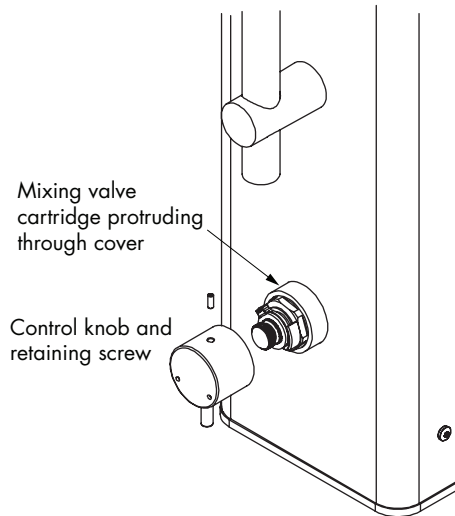

The mixing valve cartridge should protrude through the cover plate as shown.

Fit the control knob to shower cartridge and secure in position with the retaining screw.

Attach the handset to the shower hose and the shower hose to the shower connector using the sealing washers provided

Aftercare

The thermostatic shower panel and shower fittings have a high quality finish and should be treated with care.

An occasional wipe with a mild washing-up liquid on a soft damp cloth followed by a thorough rinsing is all that is required.

The nozzles in the hand set should be cleaned periodically to remove any build up of debris or deposits which may affect the performance of the shower.

Do not use an abrasive or chemical household cleaner as this may cause damage.

Calibration

The maximum factory outlet temperature setting of 41°C can be altered to suit site conditions.

WARNING: Care should be taken when altering the setting as incorrect calibration can cause injury.

- Remove control knob by unscrewing the retaining screw to expose the temperature stop rings.
- The temperature stop rings are used to control the temperature. Ring A controls the hot and ring B controls the cold water.
- Remove both rings from the cartridge and set the mixed water to the required temperature, maximum 46°C (41°C for TMV3 applications).
- Temporarily refit the control knob and using a digital thermometer it is possible to increase or reduce the mixed water outlet temperature until 41°C is re-established, by slowly rotating the handle.
- The temperature can be measured from mixed water outlet by bending the flexible hose towards the shower tray or floor of the shower.
- When the required temperature is achieved replace the two stop rings onto the splined spindle. The rings are used to set the temperature limits of the shower when in use.
- Re-assemble the control knob, secure with the retaining screw.
- The thermostatic cartridge can also be removed with the front panel in place when the control knob is removed.

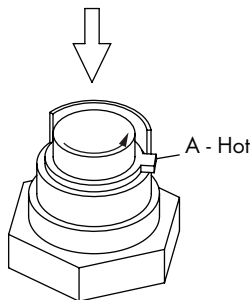
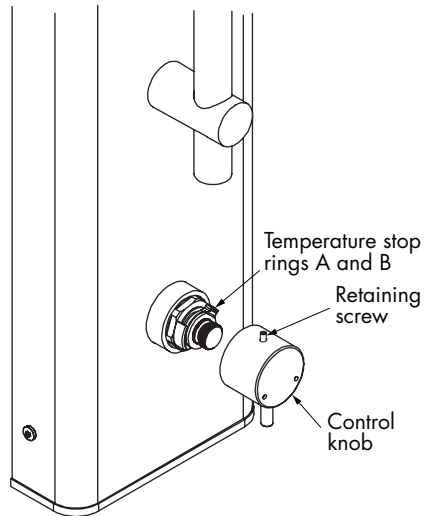

Fig. 1

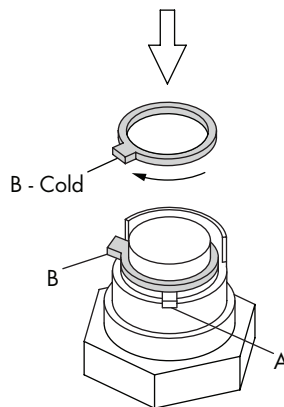

Fig. 2

Fault Finding

Fault	Diagnosis
Showering temperature is not hot enough	Ensure the hot water supply is at a sufficiently high constant temperature (55°C to 60°C). Check for airlocks in the pipework Thermostatic cartridge movement limited due to lime scale build up
The water goes cold during showering	Insufficient stored hot water supply. If a combi boiler ensure it is still firing. Ensure the hot water is circulated at a sufficiently high temperature
When the water is set at cold, the showering temperature is too hot	Hot and Cold supply connections have been reversed. Thermostatic cartridge movement limited due to lime scale build up
Maximum showering temperature is too hot or when set to hot the water runs cold	Check the commissioned maximum temperature of the valve. Check the connections to the valve are not reversed. Thermostatic cartridge movement limited due to lime scale build up
Flow of water through the valve is low	Check the filters are clean and the supply pressure is above 1.0 bar
Shower is stiff to operate	Build-up of limescale on flow control cartridge - service and de-scale
Passing/dripping from outlet	Service flow control cartridge.

TMV3 Thermostatic Shower Valve

Introduction

The thermostatic shower panel mixing valve has been specifically designed and manufactured to meet the requirements of BS 7942:2011 and NHS D08. The valve has been independently tested and approved as a TYPE 3 valve under the TMV3 scheme.

Technical Specification / Conditions for use TMV3 Valves

Outlet Temperature Adjustment Range	30°C to 50°C
Temperature Stability	±2°C
Maximum Hot Inlet Temperature	85°C
Inlet Temperature Range	55°C to 65°C: Hot Supply 5°C to 20°C: Cold Supply
DO8 Working Pressure Range	1.0 to 5.0 bar: High Pressure - HP-S
Min. Temp Differential (Mix to Hot) for Fail-Safe	10°C
Max. Pressure Inlet Differential	5 : 1

Operating Pressure Range	High Pressure
Maximum Static Pressure	10 bar
Flow Pressure, Hot and Cold	1 to 5 bar
Hot Supply Temperature	55°C to 65°C
Cold Supply Temperature	5°C to 20°C

NOTE: Valves operating outside these conditions cannot be guaranteed by the Scheme to operate as Type 3 valves.

Approvals

TMV3 Scheme Approval Number: Details Available on Request
WRAS Scheme Approval Number: Details Available on Request

Fail Safe Function

Thermostatic panel shower valves are designed to stop the mixed water flow in the event of either the hot or cold water supply failing when installed in accordance with these instructions.

To ensure full closure of the mixed water flow, the minimum temperature differential between the hot water inlet to the shower and the mixed water outlet **MUST be at least 10°C**.

Temperature Setting

Ensure that the shower valve is commissioned under normal system conditions. The valve **MUST** be commissioned to suit site conditions and the desired outlet temperature set by the installer;

- i. With normal supply conditions established and the hot and cold water supplies running, open the shower valve to its maximum temperature and leave running.
- ii. Remove the indice, retaining screw and handle.
- iii. The temperature stop rings are used to control the temperature, ring A the hot and B the cold water, see diagram on page 6.
- iv. Remove both rings from the cartridge and set the mixed water to the required temperature, maximum 41°C.
- v. Temporarily refit the handle and using a digital thermometer it is possible to increase or reduce the mixed water outlet temperature until 41°C is re-established, by slowly rotating the handle.
- vi. The stop rings are used to set the temperature limits of the shower when in use. When the required temperature is achieved replace the two stop rings on the splined spindle.

Application

The thermostatic panel thermostatic shower mixing valve has been independently tested by NSF and certified as meeting the requirements of the NHS D08 specification under the TMV3 Scheme as being suitable for use on the following designations;

Shower

HP-S

Installation

IMPORTANT - The following instructions must be read prior to the installation of any Inta shower valve. The installer should also be aware of their responsibility and duty of care to ensure that all aspects of the installation comply with all current regulations and legislation.

Flushing through water systems using certain chemicals may wholly or partially remove the lubricant from the internal workings of the valve, which may adversely affect its performance. We recommend that following a flushing of the system with chemicals, valves are checked for correct operation.

- 1 It is essential that before installing the panel shower valve to ensure that the supply conditions of the system, to which the valve is intended to be fitted, are checked to confirm compliance with the parameters as quoted within the Technical Specification and conditions on which the approval is granted i.e. verify supply temperatures, supply pressures, risk assessment.
- 2 Consideration must be made for the possibility of multiple / simultaneous demands being made on the supply system whilst the Sola shower valve is in use, all practical precautions must be made to ensure that the valve is not affected. Failure to make provision within the pipe sizing etc. will affect the performance of the valves.

Installation

- 3 The supply system to which the panel shower valve is to be installed into must be thoroughly flushed and cleaned to remove any debris, which may have accumulated during the installation. Failure to remove any debris will affect the performance and the manufacturer's warranty of the product. Independent filters / check valves and isolation valves must be fitted in conjunction with the shower valve, as close as practically possible to the water supply inlets of the panel thermostatic valve. In areas that are subject to aggressive water, provision must be made to treat the water supply prior to the supply entering any product.
- 4 The maximum flow rate of the valve will only be achieved when the supply conditions are achieved as quoted within the Technical Specification, with a flow condition under 1 bar differential pressure.
- 5 The panel shower valve has been designed for exposed surface mounted. The panel design allows access to the thermostatic mixing valve for any future maintenance that may be required to the valve or associated fittings.
- 6 The hot and cold water supplies must be connected to the valve strictly in accordance with the indications on the body of the valve i.e. hot water supply to the hot port of the valve.
- 7 In a situation where one or both of the water supplies are excessive, it is possible to fit a pressure reducing valve.
- 8 Any thermostatic shower mixing valve must be fitted with a back flow prevention device, such as check valves to prevent the cross contamination of supplies. The Sola shower valve is complete with integral insert check valves and strainers in the inlet elbows. However if required, additional WRAS approved backflow prevention devices should be positioned as close as practically possible to the water supply inlets of the panel thermostatic shower valve.
- 9 Y Pattern strainers and full-bore isolation valves must be installed in conjunction with the panel fail-safe thermostatic shower valve as close as is practically possible to the location of the valve.
- 10 It is essential that the panel fail-safe thermostatic shower valve should not be installed in situations where there is a possibility of the valve being deprived of water or where demands for water are greater than the actual stored supplies.
- 11 To ensure that the performance levels of the panel thermostatic shower valve is maintained (in the event of cold water failure), the temperature of the hot water supply at the point of entry to the valves must be a minimum of 10°C above the commissioned mixed water discharge temperature.
- 12 The panel fail-safe thermostatic shower valve must not be subject to any extreme temperature variations either during the installation or under normal operating conditions.

Commissioning

IMPORTANT: The following instructions must be read and understood prior to the commissioning the panel fail-safe thermostatic shower valves. If under any circumstances there are aspects to the installation / system which do not comply with the specification laid down, the valve **MUST NOT** be put into operation until the system / installation complies with our specification. However if all these conditions are met, proceed to set the temperature as follows;

- 1 Ensure that the system is thoroughly cleaned and free from any debris prior to the commissioning the panel fail-safe thermostatic shower valve.
- 2 Commissioning the temperatures must be carried out using a suitably calibrated thermometer preferably a digital thermometer.
- 3 In the absence of other temperatures being specified, we recommend the outlet temperature as quoted in Table 1 are used

Table 1

Application	Recommended Set Mixed Water Temperature
Shower	41°C

- 4 Each shower valve must be commissioned taking into consideration any fluctuations, which may occur within the system due to simultaneous demands. It is advisable that any outlets which are connected to the same supply as the shower valve are opened during the setting of the mixed water temperature. During commissioning it is advisable to ensure that the water temperatures are established before any attempt to commission.
- 5 Once the supply temperatures are stable and the normal operating conditions are established, the valve can be commissioned. The temperature setting can be adjusted by removing the handle from the valve body and re-positioning the temperature stop rings. We suggest that the following sequence is followed when commissioning the valve:
 - 5.1 Set the mixed water temperature to the required temperature.
 - 5.2 Measure and record the temperature of the hot and cold water supplies at the connection to the valve.
 - 5.3 Measure and record the temperature of the water discharging from the shower valve.
 - 5.4 Isolate the cold water supply to the valve and monitor the mixed water temperature.
 - 5.5 Measure and record the maximum mixed water temperature and the final temperature. The final temperature found during the test should not exceed the value quoted in Table 2
 - 5.6 Record all the equipment used during the commissioning.

Table 2

Application	Maximum Set Mixed Water Temperature
Shower	43°C

Commissioning Continued

- 6 Once the desired temperature is established replace and re-position the temperature stop rings, refit the handle.
- 7 Ensure that the application, in which the shower valve will be used, is appropriate for approved designation. The above information must be recorded and updated on every occasion when any work is carried out on the valve.

Maintenance

To ensure that the panel shower valve maintains a high level of protection, we advise the following in service testing is conducted (the same equipment used to commission the valve initially must be used in the following tasks).

- 1 After a period of between 6 and 8 weeks from commissioning carry out the following;
 - 1.1 Record the temperature of the hot and cold water supplies.
 - 1.2 Record the temperature of the mixed water from the shower valve.
- 2 If the mixed water temperature has changed significantly from the previous test results (e.g. $>1^{\circ}\text{K}$), record the change and before resetting the mixed water temperature check that:
 - 2.1 All the strainers are clean.
 - 2.2 All the check valves are in good working order.
 - 2.3 The isolation valves are fully open.
- 3 If the mixed water temperatures are acceptable, carry out the following:
 - 3.1 Record the temperature of the hot and cold water supplies.
 - 3.2 Record the temperature of the mixed water from the shower valve.
 - 3.3 Isolate the cold water supply to the mixing valve and monitor the mixed water temperature.
 - 3.4 Record the maximum temperature achieved as a result of (3.3) and the final temperature (the final temperature should not exceed the values quoted in table 2)
 - 3.5 Record the equipment used during these tests.
- 4 If the mixed water temperature is greater than the values quoted in table 2 or the maximum temperature exceeds the corresponding values from previous test results by more than 2°K , the valve must be serviced.
- 5 After a period of between 12 to 15 weeks from commissioning, carry out the sequence of tests as described in Maintenance sections 1, 2, 3 and 4.
- 6 Dependant upon the results obtained from the first two series of tests; there are a number of possible outcomes:
 - 6.1 If no significant change in the mixed water temperatures (e.g. $\leq 1^{\circ}\text{K}$) is recorded between commissioning and Maintenance sections 1 or between commissioning and Maintenance sections 5, the next in service testing should be carried out at a period of 24 to 28 weeks after initial commissioning.
 - 6.2 If a small change (e.g. 1 to 2°K) in the mixed water temperature is recorded in only one of these periods, necessitating adjustment of the mixed water temperature, then the next in service can be deferred to 24 to 28 weeks after commissioning.

Maintenance Continued

- 6.3 If small changes (e.g. 1 to 2°K) in the mixed water temperature are recorded in both of these periods, necessitating adjustment of the mixed water temperature, then the next in service test can be deferred to 18 to 21 weeks after commissioning.
- 6.4 If significant changes (e.g. > 2°K) in the mixed water temperature are recorded in both of these periods necessitating service work, then the next in service test should be carried out at 18 to 21 weeks after commissioning.
- 7 The general principle to be observed after the first 2 or 3 in-service tests is that the intervals for future tests should be set to those which previous tests have shown can be achieved with no more than a small change in mixed water temperature.
- 8 In all areas periodic maintenance of the valve and associated fittings i.e. strainers, check valves will ensure optimum performance levels are maintained.
- 9 The inlet strainers on both the hot and cold water supplies can be removed for cleaning by unscrewing the inlet union nuts and carefully pulling apart the connecting pipework.
- 10 The built in check valves can be accessed to ensure freedom and correct seating.

Spares

A full range of spares are available for this product from Inta.

PLEASE NOTE: Only genuine spares should be used.

Problem Solving

The following details are supplied for on site queries, should you require any further assistance our Technical Department can be contacted directly on 01889 272199.

1 Hot water at other outlets

- i. Operation of the insert check valves is hindered, check the valve is seated correctly.
- ii. Check Valves not fitted.
- iii. Unbalanced hot/cold supply pressure.

2 Fluctuating mixed water temperature

- i. Erratic supply temperatures at the inlets of the valve.
- ii. Starvation of the water supplied at the inlets of the valve.
- iii. Incorrect commissioning of the valve.

3 Erratic flow

- i. Insufficient water supplies.
- ii. Fluctuations in the supply pressures/temperatures.
- iii. Adverse effect created by other draw off points on the system.

4 No flow/reduced flow from shower

- i. In line filters are blocked.
- ii. Insufficient supply pressure.
- iii. Debris obstructing valve operation.
- iv. Valve requires servicing (Servicing kits available from your local stockist).

5 Valve does not fail safe when tested

- i. Installation not in accordance with our recommendations.
- ii. The minimum temperature differential not achieved.
- iii. Internal mechanism hindered by debris.

Full and detailed instructions are supplied with service kits and are available on request.

inta

Please leave this Manual for the User

To activate your product warranty please visit
www.intatec.co.uk
and click on Product Registration

inta

Intatec Ltd

Airfield Industrial Estate
Hixon
Staffordshire
ST18 0PF

Tel: **01889 272 180**

Fax: **01889 272 181**

email: **sales@intatec.co.uk**

web: **www.intatec.co.uk**

E & O.E