

NC180CP Standard Basin Mounted Mixer Tap with Temperature Regulator

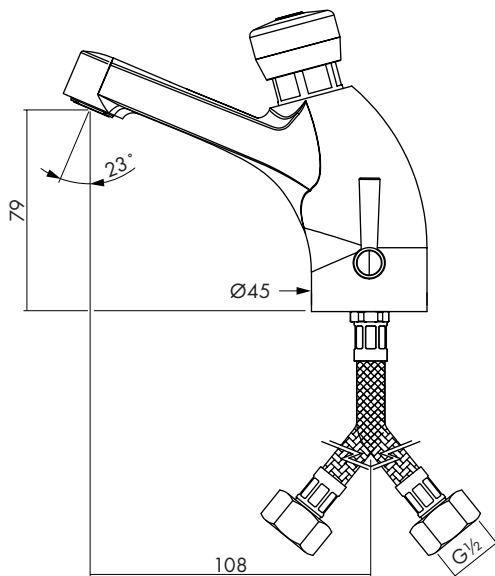

Operating Conditions

Max. Operating Pressure	10 bar
Min. Operating Pressure	0.2 bar
Maximum Inlet	65°C
Temperature Timed Flow -	15 ± 3 sec.
Max. Basin Thickness	38 mm

Water Supply (Water Fittings) Regulations 1999

Your Inta tap must be connected in accordance with the Water Byelaws.

To prevent back flow and contamination of the water supply for drinking and culinary purposes taps must provide a AUK2 or AUK3 air gap between the outlet and basin.

The NC180CP tap provides a type AUK2 air gap, for domestic usage, and a type AUK3 for non domestic locations.

It is recommended that a service valve is installed in each supply pipe or alternatively for the hot supply via a thermostatic mixing valve, which has supply connections containing an isolating valve, in order to isolate the tap should servicing be required in the future.

Installation

The NC180CP mixer tap is designed for installing in one hole basins. The easiest way to install the tap to the basin is to do so before the basin is installed when access to the retaining nut is readily available.

The installation should be thoroughly flushed and cleaned to remove any debris that may affect the performance of the tap.

Fitting to Basin

Screw the retaining screw into the threaded hole in the base of the tap taking care not to over tighten. Connect the flexible hoses to the tap and tighten noting that the cold connection is on the left and the hot is on the right when facing the tap identified by the coloured arrows

Ensure that the sealing washer is seated correctly prior to fitting the tap to the basin.

Once in place, fit the rubber gasket and retaining plate then secure in position, taking care not to over tighten the retaining nut.

Fitting to Basin Continued

Connect the flexible hoses to the hot and cold supplies remembering that the hot inlet is on the left and ensure all joints are water tight.

Note: the supply end of the flexible hose contain a rubber sealing washer, use a copper to ½" BSP parallel male coupling to connect to copper pipe.

For optimum mixing performance where the hot and cold pressures are not equal, regulating valves should be installed directly upstream of the tap so that the water supply pressures can be regulated and equalised.

Operating

The temperature of the water can be changed by moving the lever on the right side of the tap.

If the lever is pushed fully towards the back of the tap only the cold water port open; if the lever is pulled fully forward only the hot water port is open, maximum water temperature.

Whilst maintaining a constant flow from the tap move the lever forward from the cold position until the desired mixed water temperature is achieved.

Aftercare

The nozzle should be cleaned periodically to remove any build up of debris or deposits which may affect the performance.

Inta taps have a high quality finish and should be treated with care. An occasional wipe with a mild washing-up liquid on a soft damp cloth followed by a thorough rinsing is all that is required.

Do not use an abrasive or chemical household cleaner as this may cause damage.