

inta

Acura Safe Touch TMV3 Thermostatic Shower ST10010CP

Installation and Maintenance Instructions

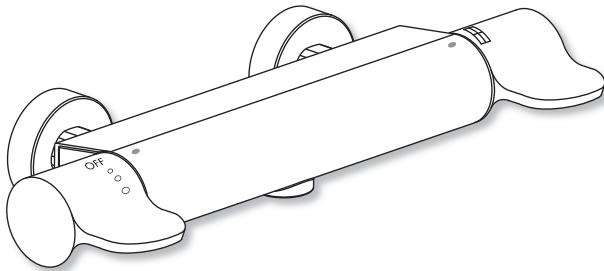

inta

Intatec Ltd
Airfield Industrial Estate
Hixon
Staffordshire
ST18 0PF

In this procedure document we have endeavoured to make the information as accurate as possible.

We cannot accept any responsibility should it be found that in any respect the information is inaccurate or incomplete or becomes so as a result of further developments or otherwise.

Tel: **01889 272 180**
email: **sales@intatec.co.uk**
web: **www.intatec.co.uk**

Introduction

This installation guide has been produced for the Acura Safe Touch shower mixing valve. These instructions cover the installation, operation and maintenance. Please read the enclosed instructions before commencing the installation of this product, please note;

We recommend that the installation of any product is carried out by an approved installer.

The installation must be carried out strictly in accordance with the Water Supply (Water Fitting) Regulations 1999 and any local authority regulations.

If in doubt we recommend that you contact WRAS - Water Regulations Advisory Scheme on Tel: 0333 207 9030, your local water authority - details available on the WRAS website or the Chartered Institute of Plumbing and Heating Engineers on Tel: 01708 472 791.

All products **MUST** be re-commissioned to suit site conditions to ensure optimum performance levels of the product are obtained.

It is recommended, especially in hard water areas, that a water softener such as the ActivFlo or ActivFlo lite be fitted to reduce the risk of calcium deposits forming.

Safety

This thermostatic shower must be installed and commissioned correctly to ensure that water is supplied at a safe temperature to suit the users.

The shower is pre-set using ideal conditions to 38°C at the stop with a manual push button override to 46°C maximum (can be re-set to suit site conditions or user preference – see calibration page 7).

The maximum mixed temperature takes account of the allowable tolerances inherent in thermostatic shower mixers and temperature losses.

It is not a safe bathing temperature for adults or children.

The British Burns Association recommends 37 to 37.5 °C as a comfortable bathing temperature for children. In premises covered by the Care Standard Act 2000, the maximum mixed water outlet temperature is 43 °C.

Products

Acura Safe Touch TMV3 Thermostatic Bar Shower

ST10010CP

Check Content

Before commencing remove all components from packaging and check each component with the contents list.

Ensure all parts are present, before discarding any packaging. If any parts are missing, do not attempt to install your *Inta* shower valve until the missing parts have been obtained.

Components

Item	Qty	Component	Item	Qty	Component
1	1	Body	6	2	Sealing washer
2	2	Wall bracket	7	2	Connector with check valve fitted
3	2	Olive	8	2	Union nut
4	2	Compression face	9	2	Concealing cylinder
5	2	Concealing plate			

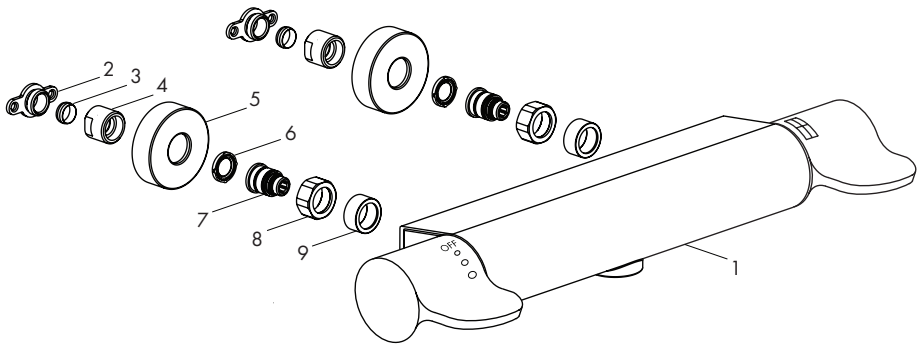

Technical Data

This Inta Safe Touch thermostatic shower valve is suitable for installations on all types of plumbing systems, including gravity supplies, fully pumped, modulating combination boiler, unvented water heater and unbalanced supplies i.e. Cold Mains & Tank Fed Hot. They are not suitable for non-modulating combination boilers.

Max Inlet Pressure (Static)	5 bar	Pre-set Factory Temp Setting	41 °C
Min Operating Pressure (Dynamic)	0.2 bar	Temperature Stability	±2 °C
Max Unbalanced Pressure Ratio	5:1	Min Temp Differential between hot inlet and mixed water outlet to achieve cold water fail safe	10 °C
Inlet Connections (Body)	G ³ / ₄ "		
Outlet Connections (Body)	G ¹ / ₂ "		
Max Inlet Temperature	85 °C		

Unvented Mains Pressure System

The drawing shows a typical installation of a shower mixing valve in conjunction with an unvented hot water system. This type of installation must be carried out in accordance with Part G of the Building Regulations.

Whilst pressures are theoretically equal (balanced) most unvented hot systems have a pressure reducing valve on the incoming cold water prior to the hot water storage vessel. This means that the hot and cold water pressures can be significantly different.

Unvented Mains Pressure System

This means that the hot and cold pressures can be significantly different.

Most unvented systems use an inlet manifold located directly after the pressure reducing valve.

It is recommended that the cold supply be taken from one of the outlets of the manifold directly to the shower as an independent supply.

For systems without a manifold unit after the pressure reducing valve and where the cold water supply pressure is significantly higher than the hot supply we recommend that a separate pressure reducing valve is fitted to the cold supply, as close as possible to the shower valve and with no draw off points between it and the shower valve.

Flow regulators are required for installations where a PRV is not fitted to ensure simultaneous demand is accounted for.

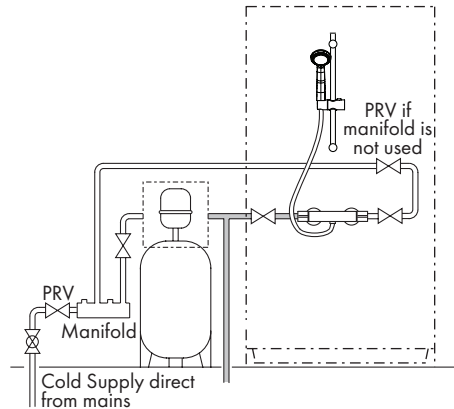

Pumped System

Pumped systems use a booster pump to increase the pressure of the gravity fed water supplies.

These booster pumps are used where the head of water is insufficient to provide a satisfactory shower or where a high performance shower is required.

Please ensure that the performance of the pump is matched to suit the shower.

Follow the instructions for gravity fed installations taking into account the installation requirements of the pump.

Ensure that the hot and cold water storage capacity is sufficient to supply the shower and any other draw off points that may be used simultaneously.

Most pumps require a minimum head of water to allow the flow switches to operate automatically. Where this is not available a negative head kit may be required to operate the pump.

Please consult the pump manufacturer's installation requirements.

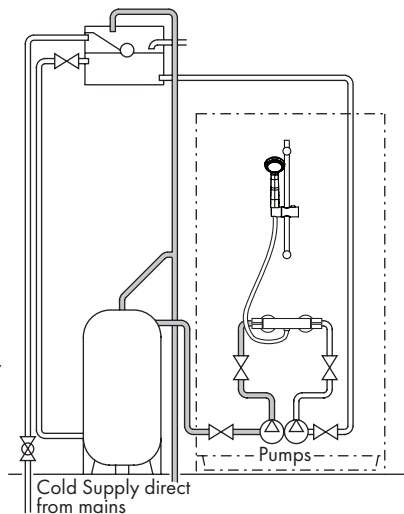

Modulating Combi Boiler / Instantaneous Gas Water Heater

The drawing shows a typical installation of a shower valve in conjunction with a combination boiler.

Combi boilers will produce a constant flow of water at a temperature within its operating range. However we recommend that the system should supply hot water in excess of 60°C.

The hot water flow rates are dependant upon the type of boiler / heater used and the temperature rise required to heat the cold water to the required temperature.

The cold water flow rates may be much greater as they are generally unrestricted from the mains cold water supply. To ensure relatively balanced flow rates, we recommend that a pressure reducing valve or 6 l/min flow regulator is fitted in the cold water supply pipe.

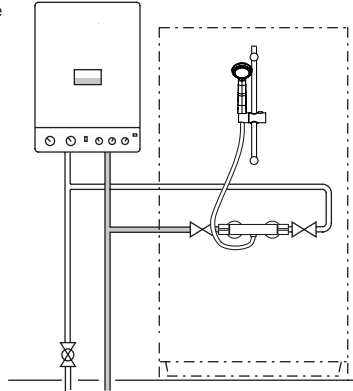

Gravity System

The drawing shows a typical installation of a shower valve on a gravity supplied system.

Please note the minimum head pressure required to ensure operation of the valve.

In accordance with good plumbing practice, we recommend that a totally independent hot and cold water supply be taken to the valve.

The cold water supply must be connected directly to the water cistern. The hot water supply should be connected to the hot water cylinder via an Essex flange or Sussex flange or to the vent or a draw off pipe as close as possible to the top of the cylinder.

For equal tank fed pressures there is no need to fit the flow regulators. This installation is the recommended minimum for gravity supplies. For systems with less than 2 metre head pressure, we recommend that a suitable booster pump is fitted to increase the supply pressure.

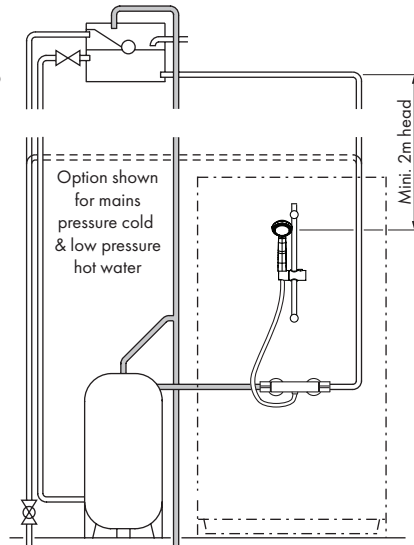

Cold Mains & Gravity Hot Supplies

If the cold supply to the shower is direct from the cold water mains and the hot water supply is gravity fed from the cold water cistern via the hot water cistern you MUST fit a pressure reducing valve or a 6 l/min flow regulator.

Dimensions

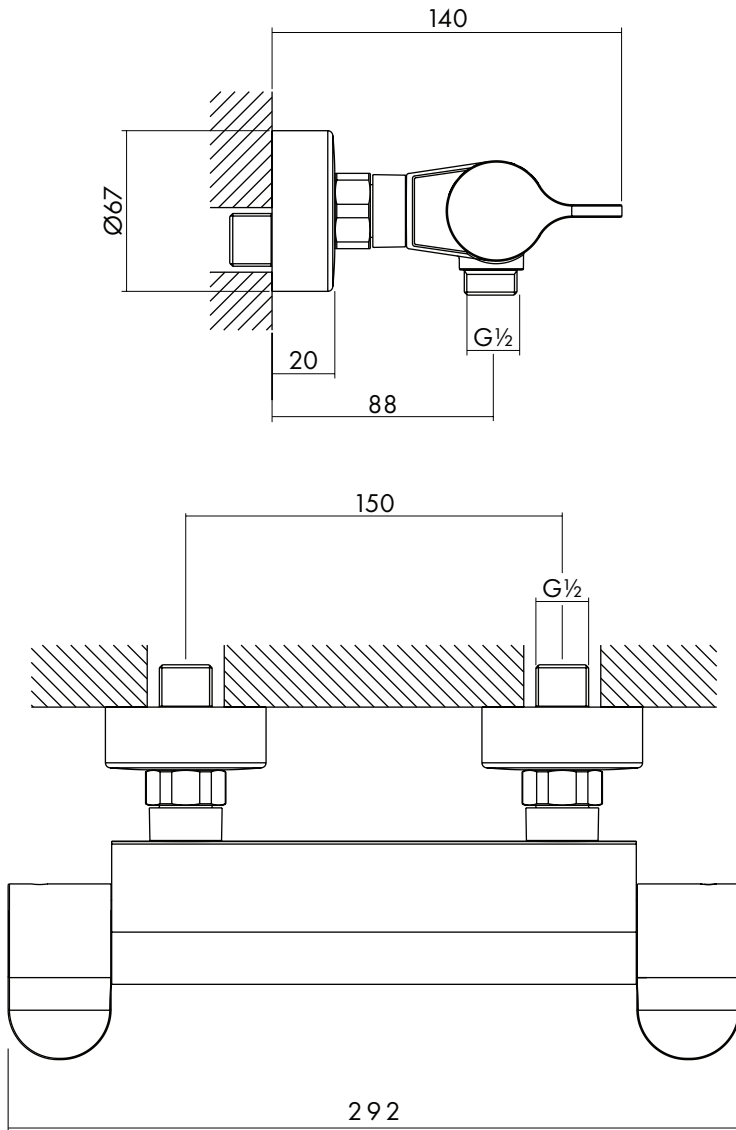

Site Preparation

It is important to plan the installation thoroughly to suit site conditions before commencing.

- Before commencing the installation ensure site conditions are suitable.
- The shower mixing valve is designed for concealed pipework, whether in a solid or studded wall.
- The thickness of wall tiles, plaster or plaster board should all be considered when routing the hot and cold supply pipes.
- The valve requires the wall brackets to have 150mm centres and sufficient copper pipe must protrude from the finished tiled surface to allow the olive and compression face to be fitted and make a water tight joint.
- Ensure the shower valve will be horizontal when installed.
- The supply pipes can come from below, above, the side before protruding through the wall.
- The supply pipes and wall brackets must be firm and secure to support the shower mixing valve. If not embedded into the wall with plaster the pipes should be fixed securely to the studding.
- Angle tap swivel connectors or compression/solder fittings can be used to connect the pipes (not supplied).
- The whole system should be thoroughly flushed, prior to the connection of the hot and cold water supplies to the shower mixing valve, to remove any debris that may be in the supply pipework.
- Ensure there are no joint leaks before finishing the wall.
- Isolation valves must be fitted in an accessible position to both the hot and cold supplies should the valve need to be isolated in the future for servicing.

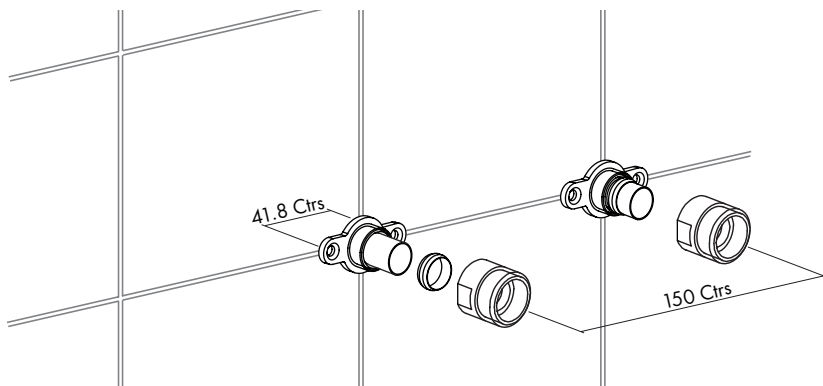

Installing the Shower Valve

- Apply silicone sealer to the back of both wall brackets, fit over the 2 protruding copper pipes, press to the wall and secure both brackets with 2 counter sunk screws.
- Add the olives and then the compression faces and tighten until water tight joints are made..
- Apply a bead of silicone sealer around the inside edge of the concealing plates, position over the compression faces and press firmly to the wall.
- Fit the shower valve to the compression faces ensuring that the sealing washers are fitted and hand tighten the union nuts.
- Using a suitably sized spanner, tighten the union nuts taking care not to damage the finish on the shower valve, do not over tighten.

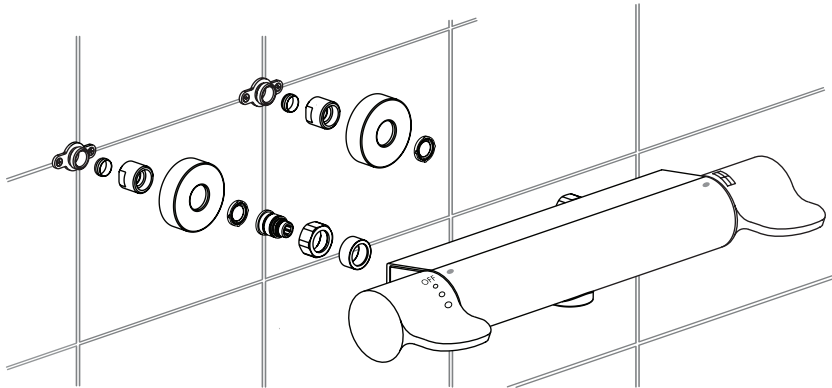

Notes:

The installation shown is for the pipework embedded in to the wall or for a stud wall.

Calibration

The Inta Acura Safe Touch shower valve has a factory set maximum outlet temperature of 41 °C via the security setting. This is based on a balanced supply pressure and a stable hot water inlet temperature of 65 °C.

However, the calibration point **MUST** be checked and re-set as necessary to suit site conditions.

Care must be taken when re-calibrating the valve as **INCORRECT CALIBRATION CAN CAUSE INJURY.**

- Unscrew the grub screw (3) and pull the control knob (2) away from the shower valve.
- Fully open the flow control (1) and allow the outlet temperature to stabilise.
- Temporarily refit the control knob (2) and using a digital thermometer it is possible to increase or reduce the mixed water outlet temperature until 41 °C is re-established, by slowly rotating the control knob.
- Refit the control knob (4) onto the splined section of the cartridge (4). The scale on the control knob (2) must align with grey dot (5) on the body. The lever part of the control knob should be in the horizontal position as shown.
- Refit the grub screw (3) into the control knob and tighten to secure the control knob.

PLEASE NOTE THAT ONCE CALIBRATED, THE SECURITY SETTING WILL ONLY BE 41 °C UNDER THE SUPPLY CONDITIONS USED FOR CALIBRATION.

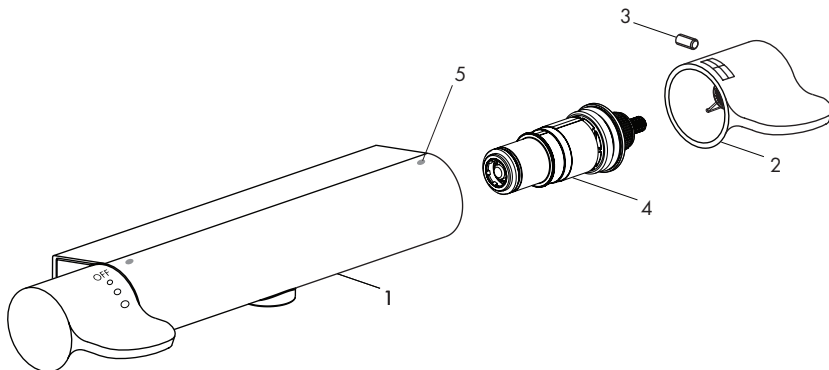

Cartridge Replacement

- Isolate both the hot and cold water supplies
- Unscrew the grub screw (3) and pull the control knob (2) away from the shower valve.
- Using a suitable spanner unscrew the cartridge (4).
- Replace with a new cartridge.
- Refit the control knob (2) onto the splined section of the cartridge.
- Refit the control knob (4) onto the splined section of the cartridge (4). The scale on the control knob (2) must align with grey dot (5) on the body. The lever part of the control knob should be in the horizontal position as shown.
- The shower valve must be re-calibrated after fitting the new cartridge following the procedure above.

Aftercare

Inta shower mixing valves have a high quality finish and should be treated with care.

An occasional wipe with a mild washing-up liquid on a soft damp cloth followed by a thorough rinsing is all that is required.

The nozzles in the hand set or overhead soaker should be cleaned periodically to remove any build up of debris or deposits which may affect the performance of the shower.

Do not use an abrasive or chemical household cleaner as this may **cause damage**.

Spares

A full range of spares are available for this product.

PLEASE NOTE: Only genuine spares should be used.

Problem Solving

The following details are supplied for on site queries, should you require any further assistance our Technical Department can be contacted directly on 01889 272199.

Fault	Diagnosis
Showering temperature is not hot enough	Ensure the hot water supply is at a constant temperature of 60 °C. Check for air locks in the pipework. Thermostatic cartridge movement limited due to lime scale build up
The water goes cold during showering	Insufficient stored hot water. When used with a combi boiler confirm that the boiler is still firing. Adjust the boiler to 65 °C which may not necessarily be the best flow rate.
When the water is set at cold, the showering temperature is too hot	Hot and Cold supply connections have been reversed. Thermostatic cartridge movement limited due to lime scale build up
Maximum showering temperature is too hot or when set to hot the water runs cold	Check the commissioned maximum temperature of the valve. Check the connections to the valve are not reversed. Thermostatic cartridge movement limited due to lime scale build up
Flow of water through the valve is low	Check the filters are clean and the supply pressure is above 0.2 bar
No flow of water	Ensure the valve has not fail-safed, and check that there is hot and cold water flow to the valve. Ensure the check valves are not closed
Shower is stiff to operate	Build-up of limescale on flow control cartridge - service and de-scale
Passing/dripping from outlet	Service flow control cartridge.

Safe Touch TMV3 Thermostatic Shower Valve

Introduction

The Acura Safe Touch thermostatic shower mixing valve has been specifically designed and manufactured to meet the requirements of BS 7942: 2000 and NHS D08. The valve has been independently tested and approved as a TYPE 3 valve under the TMV3 scheme.

Technical Specification / Conditions for use TMV3 Valves

Outlet Temperature Adjustment Range	30 °C to 50 °C
Temperature Stability	± 2 °C
Maximum Hot Inlet Temperature	85 °C
Inlet Temperature Range	55 °C to 65 °C : Hot Supply 5 °C to 20 °C : Cold Supply
DO8 working Pressure Range	0.2 to 1.0 bar : Low Pressure - LP-SE 1.0 to 5.0 bar : High Pressure - HP-S
Min Temp Differential (Mix to Hot) for Fail-Safe	10 °C
Max. Pressure Inlet Differential	5:1
Max. Flow Rate @ 1 bar Differential	Ø15mm 1500 l/h (25 l/m) Ø22mm 1700 l/h (28.3 l/m)

Operating Pressure Range	High Pressure	Low Pressure
Maximum Static Pressure	10 bar	10 bar
Flow Pressure, Hot and Cold	1 to 5 bar	0.2 to 1 bar
Hot Supply Temperature	55 °C to 65 °C	55 °C to 65 °C
Cold Supply Temperature	5 °C to 20 °C	5 °C to 20 °C

NOTE: Valves operating outside these conditions cannot be guaranteed by the Scheme to operate as Type 3 valves.

Approvals

TMV3 Scheme Approval Number:
WRAS Scheme Approval Number:

Details Available on Request
Details Available on Request

Fail Safe Function

Safe Touch shower valves are designed to reduce or stop the mixed water flow in the event of either the hot or cold water supply failing when installed in accordance with these instructions. To ensure thermal shut off the mixed water flow the minimum temperature differential between the hot water inlet to the valve and the mixed water outlet **MUST be at least 10 °C**.

Temperature Setting

Ensure that the shower valve is commissioned under normal system conditions. The valve **MUST** be commissioned to suit site conditions and the desired outlet temperature set by the installer;

- With normal supply conditions established and the hot and cold water supplies running, open the shower valve to its maximum temperature and leave running.
- Remove the cover (2), retaining screw (3) and temperature control knob (4) by pulling away from the shower valve and the temperature stop ring (5).
- Fully open the flow control (1) and allow the outlet temperature to stabilise.
- Temporarily refit the control knob (4) and using a digital thermometer it is possible to increase or reduce the mixed water outlet temperature until 41 °C is re-established, by slowly rotating the control knob.
- Remove the control knob (4) and refit the temperature stop ring (5) onto the splined section of the cartridge. The red dot on the temperature stop ring must align with the temperature position symbol (7) on the valve body.
- Refit the temperature control knob in the reverse order ensuring that 41 °C on the control knob is in line with the temperature position symbol (7).

PLEASE NOTE THAT ONCE CALIBRATED, THE SECURITY SETTING WILL ONLY BE 41 °C UNDER THE SUPPLY CONDITIONS USED FOR CALIBRATION.

Application

The Safe Touch thermostatic shower mixing valve has been independently tested by NSF and certified as meeting the requirements of the NHS D08 specification under the TMV3 Scheme as being suitable for use on the following designations;

Shower

HP-S

Installation

IMPORTANT - The following instructions must be read prior to the installation of any Inta shower valve. The installer should also be aware of their responsibility and duty of care to ensure that all aspects of the installation comply with all current regulations and legislation.

Flushing through water systems using certain chemicals may wholly or partially remove the lubricant from the internal workings of the valve, which may adversely affect its performance. We recommend that following a flushing of the system with chemicals, valves are checked for correct operation.

Installation Continued

- 1 It is essential that before installing a Safe Touch shower valve to ensure that the supply conditions of the system, to which the valve is intended to be fitted, are checked to confirm compliance with the parameters as quoted within the Technical Specification and conditions on which the approval is granted i.e. verify supply temperatures, supply pressures, risk assessment.
- 2 Consideration must be made for the possibility of multiple / simultaneous demands being made on the supply system whilst the Safe Touch shower valve is in use, all practical precautions must be made to ensure that the valve is not affected. Failure to make provision within the pipe sizing etc. will affect the performance of the valves.
- 3 The supply system to which the Safe Touch shower valve is to be installed into must be thoroughly flushed and cleaned to remove any debris, which may have accumulated during the installation. Failure to remove any debris will affect the performance and the manufacturer's warranty of the product. Independent filters / check valves and isolation valves must be fitted in conjunction with the shower valve, as close as practically possible to the water supply inlets of the Safe Touch thermostatic valve. In areas that are subject to aggressive water, provision must be made to treat the water supply prior to the supply entering any product.
- 4 The maximum flow rate of the valve will only be achieved when the supply conditions are achieved as quoted within the Technical Specification, with a flow condition under 1 bar differential pressure.
- 5 The Safe Touch shower valve has been designed to be surface mounted horizontally. It is essential that the access to the valve is not obstructed for any future maintenance that may be required to the valve or associated fittings.
- 6 The hot and cold water supplies must be connected to the valve strictly in accordance with the indications on the body of the valve i.e. hot water supply to the hot port of the valve.
- 7 In a situation where one or both of the water supplies are excessive, it is recommended to fit a Pressure Reducing Valve to reduce the pressure(s) to within the limits as quoted previously.
- 8 Any thermostatic shower valve must be fitted with a back flow prevention device, such as check valves to prevent the cross contamination of supplies. The thermostatic shower valve is supplied complete with integral insert check valves and strainers.
- 9 Y Pattern strainers and full-bore isolation valves must be installed in conjunction with the Safe Touch fail-safe thermostatic shower valve as close as is practically possible to the location of the valve.
- 10 It is essential that the Safe Touch fail-safe thermostatic shower valve should not be installed in situations where there is a possibility of the valve being deprived of water or where demands for water are greater than the actual stored supplies.

Installation Continued

- 11 To ensure that the performance levels of the Safe Touch thermostatic shower valve is maintained (in the event of cold water failure), the temperature of the hot water supply at the point of entry to the valves must be a minimum of 10 °C above the commissioned mixed water discharge temperature.
- 12 The Safe Touch fail-safe thermostatic shower valve must not be subject to any extreme temperature variations either during the installation or under normal operating conditions.

Commissioning

IMPORTANT - The following instructions must be read and understood prior commissioning the Safe Touch fail-safe thermostatic shower valves. If under any circumstances there are aspects to the installation / system which do not comply with the specification laid down, the valve **MUST NOT** be put into operation until the system / installation complies with our specification. However if all these conditions are met, proceed to set the temperature as follows;

- 1 Ensure that the system is thoroughly cleaned and free from any debris prior to the commissioning the Safe Touch fail-safe thermostatic shower valve.
- 2 Commissioning the temperatures must be carried out using a suitably calibrated thermometer preferably a digital thermometer.
- 3 In the absence of other temperatures being specified, we recommend the outlet temperature quoted in Table 1 are used.

Table 1

Application	Recommended Set Mixed Water Temp.
Shower	41 °C

- 4 Each shower valve must be commissioned taking into consideration any fluctuations, which may occur within the system due to simultaneous demands. It is advisable that any outlets which are connected to the same supply as the shower valve are opened during the setting of the mixed water temperature. During commissioning it is advisable to ensure that the water temperatures are established before any attempt to commission.
- 5 Once the supply temperatures are stable and the normal operating conditions are established, the valve can be commissioned. The temperature setting can be adjusted by removing the handle from the valve body and re-positioning the temperature stop rings. We suggest that the following sequence is followed when commissioning the valve:
 - 5.1 Set the mixed water temperature to the required temperature.
 - 5.2 Measure and record the temperature of the hot and cold water supplies at the connection to the valve.
 - 5.3 Measure and record the temperature of the water discharging from the shower valve.
 - 5.4 Isolate the cold water supply to the valve and monitor the mixed water temperature.

Commissioning Continued

- 5.5 Measure and record the maximum mixed water temperature and the final temperature
The final temperature found during the test should not exceed the value quoted in Table

Table 2

Application	Maximum Set Mixed Water Temp.
Shower	43 °C

- 6 Once the desired temperature is established replace and re-position the temperature stop rings, refit the handle.
- 7 Ensure that the application, in which the shower valve will be used, is appropriate for approved designation. The above information must be recorded and updated on every occasion when any work is carried out on the valve.

Maintenance

To ensure that the Safe Touch shower valve maintains a high level of protection, we advise the following in service testing is conducted (the same equipment used to commission the valve initially must be used in the following tasks).

- 1 After a period of between 6 and 8 weeks from commissioning carry out the following;
 - 1.1 Record the temperature of the hot and cold water supplies.
 - 1.2 Record the temperature of the mixed water from the shower valve.
- 2 If the mixed water temperature has changed significantly from the previous test results (e.g 1 °K), record the change and before resetting the mixed water temperature check that:
 - 2.1 All the strainers are clean.
 - 2.2 All the check valves are in good working order.
 - 2.3 The isolation valves are fully open.
- 3 If the mixed water temperatures are acceptable, carry out the following:
 - 3.1 Record the temperature of the hot and cold water supplies.
 - 3.2 Record the temperature of the mixed water from the shower valve.
 - 3.3 Isolate the cold water supply to the mixing valve and monitor the mixed water temperature.
 - 3.4 Record the maximum temperature achieved as a result of (3.3) and the final temperature (the final temperature should not exceed the values quoted in table 2)
 - 3.5 Record the equipment used during these tests.

Maintenance Continued

- 4 If the mixed water temperature is greater than the values quoted in table 2 or the maximum temperature exceeds the corresponding values from previous test results by more than 2 °K, the valve must be serviced.
- 5 After a period of between 12 to 15 weeks from commissioning, carry out the sequence of tests as described in Maintenance sections 1, 2, 3 and 4.
- 6 Dependant upon the results obtained from the first two series of tests; there are a number of possible outcomes:
 - 6.1 If no significant change in the mixed water temperatures (e.g. $\leq 1^\circ\text{K}$) is recorded between commissioning and Maintenance sections 1 or between commissioning and Maintenance sections 5, the next in service testing should be carried out at a period of 24 to 28 weeks after initial commissioning.
 - 6.2 If a small change (e.g. 1 to 2°K) in the mixed water temperature is recorded in only one of these periods, necessitating adjustment of the mixed water temperature, then the next in service can be deferred to 24 to 28 weeks after commissioning.
 - 6.3 If small changes (e.g. 1 to 2°K) in the mixed water temperature are recorded in both of these periods, necessitating adjustment of the mixed water temperature, then the next in service test can be deferred to 18 to 21 weeks after commissioning.
 - 6.4 If significant changes (e.g. $> 2^\circ\text{K}$) in the mixed water temperature are recorded in both of these periods necessitating service work, then the next in service test should be carried out at 18 to 21 weeks after commissioning.
- 7 The general principle to be observed after the first 2 or 3 in-service tests is that the intervals for future tests should be set to those which previous tests have shown can be achieved with no more than a small change in mixed water temperature.
- 8 In all areas periodic maintenance of the valve and associated fittings i.e. strainers, check valves will ensure optimum performance levels are maintained.
- 9 The inlet strainers on both the hot and cold water supplies can be removed for cleaning by unscrewing the inlet union nuts and carefully pulling apart the connecting pipework.
- 10 The built in check valves can be accessed to ensure freedom and correct seating.

Spares

A full range of spares are available for this product from Inta.

PLEASE NOTE: Only genuine spares should be used.

Notes

Notes

inta

Please leave this Manual for the User

To activate your product warranty please visit

www.intatec.co.uk

and click on Product Registration

inta

Intatec Ltd

Airfield Industrial Estate

Hixon

Staffordshire

ST18 0PF

Tel: **01889 272 180**

email: **sales@intatec.co.uk**

web: **www.intatec.co.uk**

E & O.E

© Intatec Ltd 2025

06-10-25