

NC177CP Contemporary Basin Mounted Non Concussive Tap

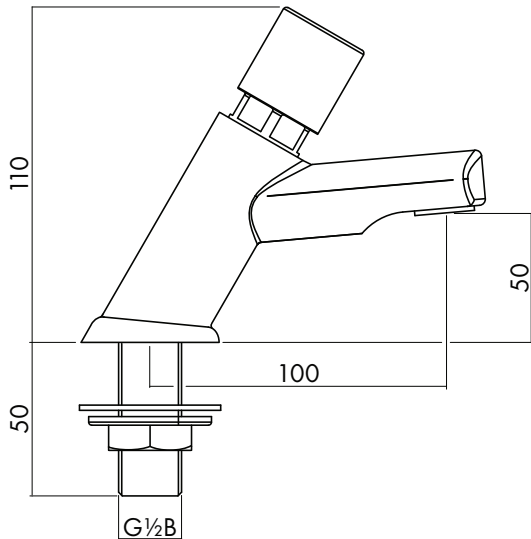

Products

- NC177CP adjustable flow time non concussive basin mounted tap with anti-block feature - pair
- NC177CP(s) adjustable flow time non concussive basin mounted tap with anti-block feature - single tap

Operating Conditions

Max. Operating Pressure	10 bar
Min. Operating Pressure	0.5 bar
Max. Inlet Temperature	65 °C
Timed Flow - Factory Set	15 ± 5 sec @ 1 bar
Adjustable Flow Time Range	3±2 to 30 +5/-10 seconds at 3 bar
Flow Rate Regulator Options	2, 4 and 5 litre
Max. Basin Thickness	26mm

Water Byelaws

Your Inta taps must be connected in accordance with the Water Byelaws.

To prevent back flow and contamination of the water supply for drinking and culinary purposes taps must provide an **AUK2** or **AUK3** air gap between the outlet and basin.

Inta basin taps provide a type **AUK2** air gap, for domestic usage, and a type **AUK3** for non domestic locations.

In order to prevent scalding, the hot water tap should be connected to the hot water supply via a thermostatic mixing valve.

Water Byelaws Continued

It is recommended that a service valve is installed in the cold water supply pipe and the thermostatic mixing valve should have connections containing an isolating valve, in order to isolate the tap should servicing be required in the future.

Installation

The easiest way to install the taps to the basin is to do so before the basin is installed when access to the backnuts is readily available.

The tap marked for the hot water **RED** should be fitted on the left side when facing the basin and for the cold water **BLUE** on the right.

If replacing existing taps ensure the water supply is turned off and that the old taps are completely removed.

Fitting to Basin

Insert the threaded inlet through the hole in the basin. Fit the rubber washer and back nut onto the threaded inlet to secure the tap. Do not over tighten the backnut.

Use a swivel connector with a fibre washer (tap connector) to connect the water supply and make a water tight joint.

Note if replacing existing taps the threaded inlet may be shorter than the original taps.

Repeat the operation for the second tap.

Turn on the water supply to both taps and run the water for a couple of minutes to check for leaks.

NC177CP Contemporary Basin Mounted Non Concussive Tap

Adjusting the Flow Time

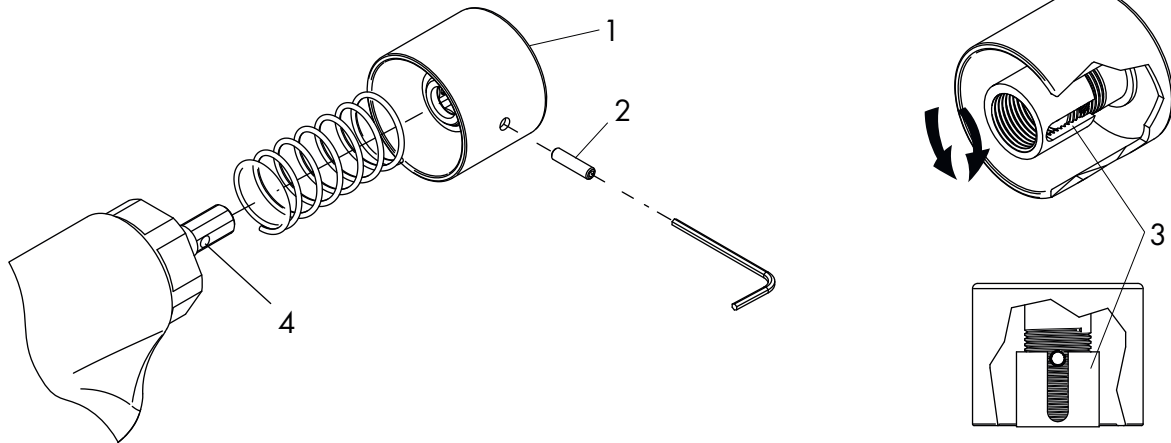

Adjusting the Flow Time

- 1 Remove button head (1) by removing the grub screw (2) using the 1.5mm Allen key (supplied) taking care to prevent the spring from escaping in an uncontrolled manner.
- 2 Adjustment to the timed flow can be achieved by turning the stop ring (3) clockwise to increase the length of timed flow and anti-clockwise to reduce it.
- 3 Make sure the slot in the stop ring is orientated to allow the grub screw to be returned to its original position and enter the hole in the spindle (4) of the flow cartridge.
- 4 To re-assemble the button head to the cartridge spindle in the reverse order taking care when refitting the spring.
- 5 Test the tap several times to confirm the desire flow time has been achieved.

Aftercare

Inta taps have a high quality finish and should be treated with care.

An occasional wipe with a mild washing-up liquid on a soft damp cloth followed by a thorough rinsing is all that is required.

Do not use an abrasive or chemical household cleaner as this may cause damage.