



Product

IT1005RS - Intatherm Safe Touch TMV3 Thermostatic Basin Mixer Tap with Detachable Spout & Copper Tails (TP6)

IT1006RS - Intatherm Safe Touch TMV3 Thermostatic Basin Mixer Tap with Detachable Spout, Extended Lever & Copper Tails (TP6)

Technical Specification

Max Inlet Pressure (static):	10 Bar
Min Inlet Pressure (dynamic):	0.2 Bar
Max Inlet Temperature:	85°C
Factory Pre-set Temperature:	43°C with max temp stop
Temperature Stability:	+/-2°C
Inlet Connections:	M10 Copper Tails
Min temperature differential to achieve hot or cold failsafe:	10°C
System Installation:	Unvented, Pressurised, Gravity & Combination

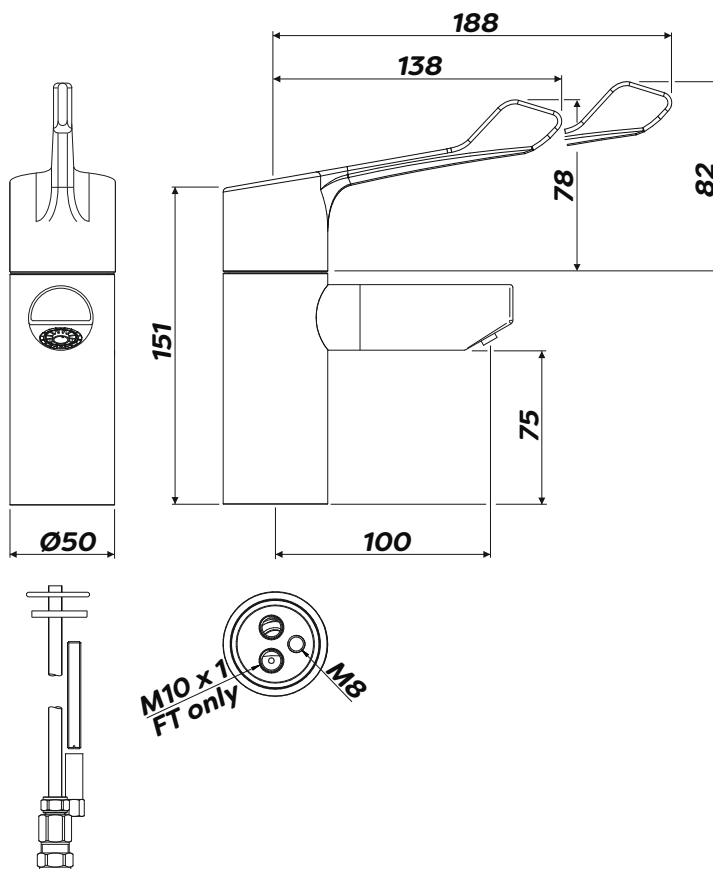

Additional Information

Long lever to aid users with limited dexterity

Detachable spout

Thermostatic sequential control

Anti-scald fail-safe technology

Copper inlet connections

Self draining spout

DDA compliant

WRAS & TMV3 Approved

Flow Rates

Pressure (Bar)	0.25	0.5	0.75	1.0	1.5	2.0	2.5	3.0	3.5	4.0
Flow (L/m)	7.2	9.1	11.2	13.4	15.0	17.6	19.8	21.4	22.7	23.9



Intatec, Airfield Industrial Estate, Hixon, Stafford, ST18 0PF

T. 01889 272180 F. 01889 272181 E. sales@intatec.co.uk

www.intatec.co.uk