

## Dimensions

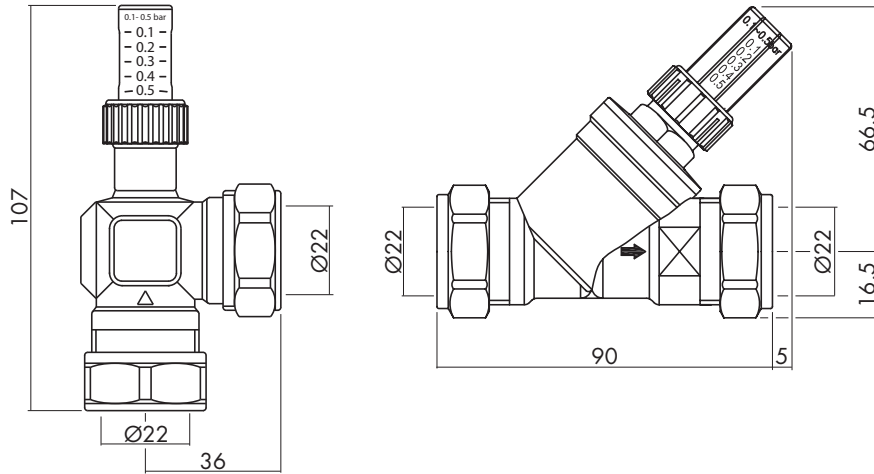

**ABPA401022**

**ABPS402022**

## Automatic Differential Bypass Valve ABPA401022 & ABPS402022 Installation and Maintenance Instructions

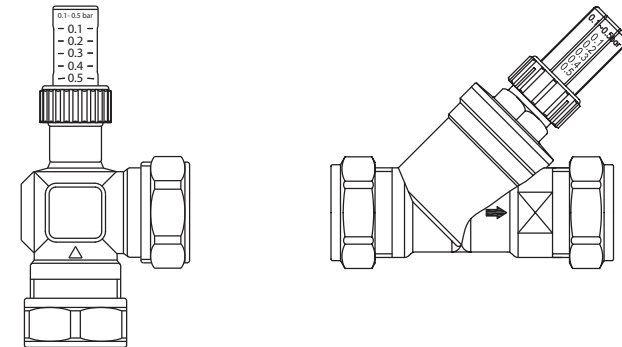

**Intatec Ltd**  
Airfield Industrial Estate  
Hixon  
Staffordshire  
ST18 0PF

Tel: **01889 272 180**  
Fax: **01889 272 181**  
email: [sales@intatec.co.uk](mailto:sales@intatec.co.uk)  
web: [www.intatec.co.uk](http://www.intatec.co.uk)

**Intatec Ltd**  
Airfield Industrial Estate  
Hixon  
Staffordshire  
ST18 0PF

Tel: **01889 272 180**  
Fax: **01889 272 181**  
email: [sales@intatec.co.uk](mailto:sales@intatec.co.uk)  
web: [www.intatec.co.uk](http://www.intatec.co.uk)

In this procedure document we have endeavoured to make the information as accurate as possible.

We cannot accept any responsibility should it be found that in any respect the information is inaccurate or incomplete or becomes so as a result of further developments or otherwise.

## Application

These automatic bypass valves (ABV) are suitable for all heating systems up to 10 bar static pressure where a boiler bypass is required or where thermostatic radiator valves (TRV) are installed.

The ABV provides a simple method of ensuring adequate flow through boilers which require a bypass as well as reducing system noise.

In systems fitted with thermostatic radiator valves, the ABV opens automatically as the TRVs or zone valves start to close and the resistance of the systems starts to exceed the preset pressure of the ABV.

Automatic bypass valves are particularly beneficial in improving the efficiency by bypassing the system when necessary and also improving the control of systems fitted with TRVs, by ensuring a constant differential pressure across the radiator.

## Installation

The ABV should be fitted immediately after the pump between the flow and return pipes.

Pipework should be 22mm to accommodate maximum capacity and the flow through the valve must be in the direction of the arrow marked on the body.

## Specification

Maximum Working Pressure:	10 bar
Maximum Working Temperature:	100 °C
Flow Capacity:	1 to 5 m <sup>3</sup> /h
Connections:	22mm compression
Differential Pressure Range:	0.1 to 0.5 bar

## Function

Automatic Bypass valves perform two functions:

- As a boiler bypass as required by the boiler manufacturer.
- As a system bypass to accommodate pump overrun and to alleviate system noise that can be caused by increased pressures when TRVs or zone valves start to close.

## Setting

The valves can be manually adjusted from 0.1 to 0.5 bar.

The flow chart shows the flow curve for the individual settings. A setting of 0.2 to 0.3 bar is sufficient for most common installations.

Ideally the pump curve should be plotted onto the chart to indicate the correct setting.

When the Delta P of the pump is unknown, setting the ABV is accomplished as follows:

- Set the bypass valve to 0.5 bar

## Setting

- Open all radiator valves including any zone valves present for the control of hot water cylinders or other heat sources.
- Ensure the pump is set correctly to adequately heat all of the system demands.
- While the system is heating at full capacity, gradually turn the adjustment knob of the bypass valve towards 0.1 bar until you begin to feel the outlet pipe from the bypass valve begin to feel warm.
- Once this heat is felt, turn the setting back towards 0.5 bar by half a turn to prevent constant flow.
- The valve will now only begin to bypass when the various TRVs and other variable control devices begin to close in response to room/zones temperature increases.
- One at a time, slowly close the TRVs and recheck for system or boiler noise. If excessive noise can be heard slowly decrease the setting on the bypass valve until it stops.

**NOTE:** On new or modified installations the above setting routine should be carried out as part of the system commissioning procedure, which includes system flushing to BS 7593.

## Flow Chart and Kv Values

