

IntaKlean Nano IKN22 Installation & Servicing Instructions

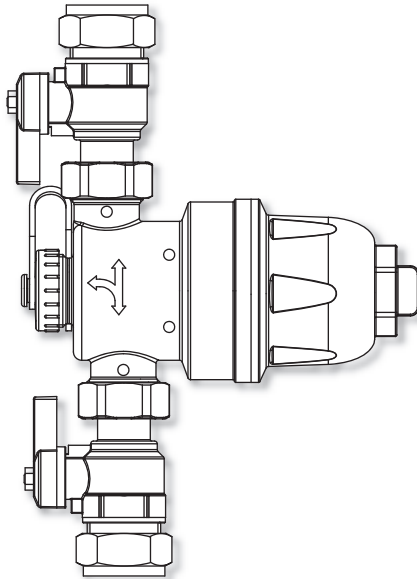

inta

Intatec Ltd

Airfield Industrial Estate
Hixon
Staffordshire
ST18 0PF

In this procedure document we have endeavoured to make the information as accurate as possible.

We cannot accept any responsibility should it be found that in any respect the information is inaccurate or incomplete or becomes so as a result of further developments or otherwise.

Tel: **01889 272 180**

Fax: **01889 272 181**

email: **sales@intatec.co.uk**

web: **www.intatec.co.uk**

LOCATION

The IntaKlean Nano is a magnetic system filter designed to remove ferrous and non ferrous material from fluid systems.

For maximum system component protection we advise that the IntaKlean Nano is installed onto the return leg of the circuit, between the last radiator and the boiler.

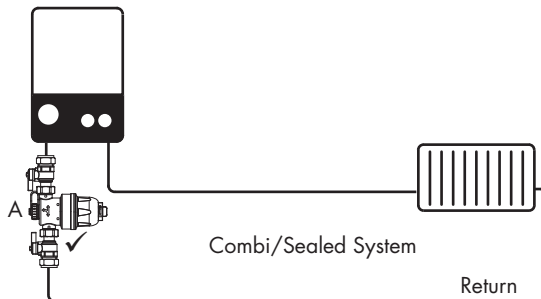
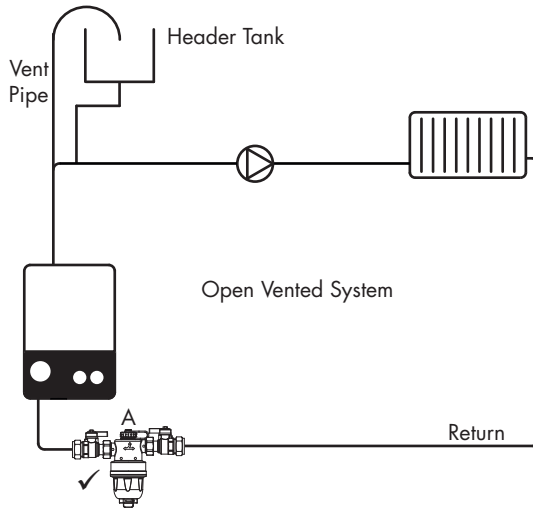

LOCATION

The IntaKlean Nano can be configured to suit site conditions with the position of the 2 ball valve and drain utilising any of the 3 connections on the filter pot.

Ensure that the system is drained down and all system pressure has been released.

On open vented systems, make sure that the feed and expansion tank is isolated.

When siting the IntaKlean Nano magnetic system filter, great care should be taken to place the filter so that access for the removable magnetic probe and drain plug is available. Doing this will aid the servicing of the filter and any chemical dosing in the future.

COMPONENTS

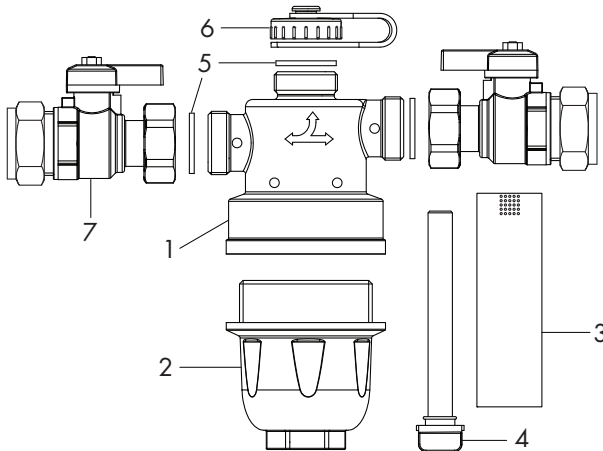

Item	Qty	Component
1	1	Filter pot
2	1	Transparent cap
3	1	Filter cartridge
4	1	Magnet
5	3	Sealing washer
6	1	Drain cap and strap
7	2	Ball valves

INSTALLATION

If an existing system, drain the heating system and locate the return pipe where the IntaKlean Nano will be located.

If a new system locate the return pipe.

The whole system should be thoroughly flushed, prior to fitting the IntaKlean Nano, to remove any debris that may be in the supply pipework.

Installation steps:

1. Mark out the section required in the pipework, cut the section out as necessary.

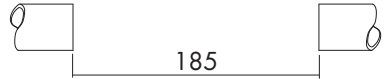

2. Assemble the compression connection end of each ball valve onto each side of the cutout pipework and tighten



3. Offer the filter body in between the ball valves, locate the sealing washer in place, tighten accordingly.

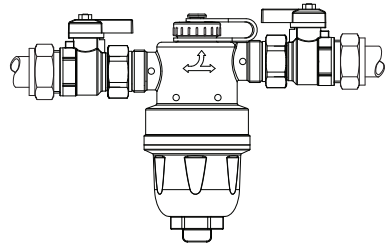

4. Move the handle of each isolating ball valve to the closed position.

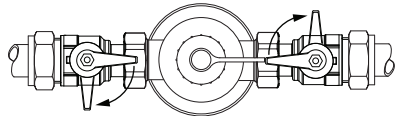

5. Fill the system with fluid.

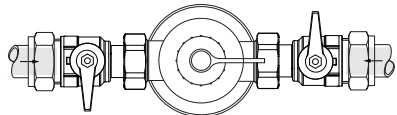

6. Open both isolating valves and check for leaks.

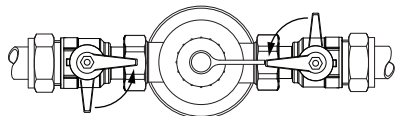

DIMENSIONS

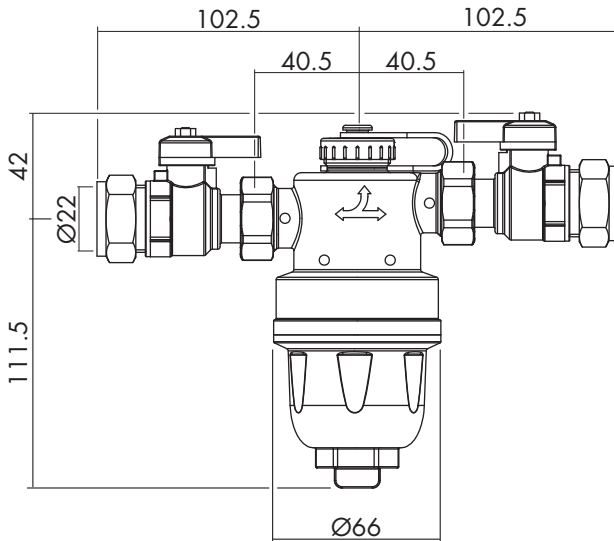

COMMISSIONING

The commissioning procedure should be carried out as follows;

- 1 Making sure that all open ends of the system are closed, begin to refill the system.
- 2 Bleed radiators as required.
- 3 Open any manual air vents installed in the system to release any trapped air.

N.B. – Air may continue to be present in system pipework for a small period as the central heating is run after installation of the IntaKlean Nano. We recommend that you check the radiators and air vents again to ensure that all air has been purged from the system.

CLEANING AND SERVICING

We recommend that the IntaKlean Nano is serviced once every twelve months or in line with the servicing schedule of the boiler, or according to water conditions.

Prior to cleaning the IntaKlean Nano ensure that the working environment is safe.

Inta recommend that the boiler is turned off before commencing any maintenance works. Caution should also be taken regarding the temperature of the contents of the filter.

CLEANING AND SERVICING CONTINUED

The method of draining and cleaning the filter will vary depending upon the orientation and space available, the method described is just an example.

1. Isolate IntaKlean Nano from the system by shutting the isolating ball valves.
2. Rotate the magnet to disengage it and allow it to be withdrawn.
3. Loosen the 2 union nuts sufficiently to allow the filter pot to be rotated so that the drain is at the bottom.
4. Place a suitable container underneath the filter and remove the drain cap.
5. Allow the filter contents to drain into the container and replace the cap.
6. Rotate the filter pot back to its original position and re-tighten the union nuts
7. Using a suitably sized spanner on the hexagon at the top of the transparent cap unscrew and remove the filter cartridge.
8. Remove any residual debris from both the filter pot and transparent cap using a soft cloth or disposable paper towel and rinse in clean water.
9. Rinse the filter cartridge in clean water to remove any debris.
10. Re-assemble the filter and re-commission as detailed in the **COMMISSIONING** section of these instructions. Ensure that the **SERVICE SCHEDULE** is completed each time the filter is serviced.
11. Replace the 'O' ring cap seals if damaged.

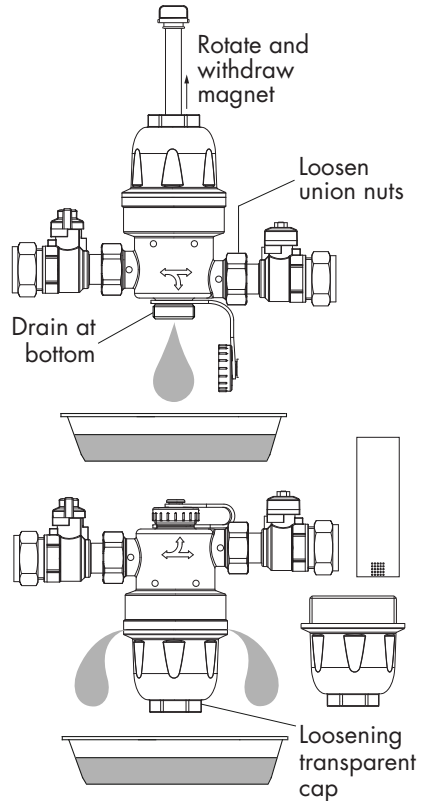

WARNING - EXCESSIVE TIGHTENING OF THE CAP TO THE FILTER POT MAY IRREPARABLY DAMAGE THE FILTER.

CHEMICAL DOSING

To dose the system using the IntaKlean Nano, follow the below procedure;

1. The drain cap should be in upper position on the filter pot.
2. Ensure the working environment is safe and the boiler is turned off at the switch.
3. Isolate the IntaKlean Nano from the system by shutting the isolating valve closest to the boiler with the other ball valve open.
4. Place a suitable container underneath the filter and remove the drain cap.
5. Allow any leakage to drain into a container.
6. Add the dosing chemicals via the drain connection.
7. Allow the dosing chemical to flow into the main pipework system.
8. Repeat until the specified amount of chemicals have introduced in the system.
9. Re-commission the system as per the previous instructions in the **COMMISSIONING** section.

10. Complete the **SERVICE SCHEDULE** below..

SERVICE SCHEDULE

Service Number	Date	Attending engineer	Tick as appropriate			
			Filter contents drained	Filter disassembled and cleaned	Inhibitor added	System cleanser added
1						
2						
3						
4						
5						
6						
7						
8						
9						
10						

TECHNICAL SUPPORT & WARRANTY

The IntaKlean Nano magnetic central heating system filter is covered by a two year warranty against manufacturing fault.

To register your product for warranty, please visit www.intatec.co.uk.

For technical assistance, please contact our dedicated technical support line on 01889 272 199.

Please Leave this Manual for the User

To activate your product warranty please visit

www.intatec.co.uk

and click on Product Registration

inta

Intatec Ltd

Airfield Industrial Estate

Hixon

Staffordshire

ST18 0PF

Tel: **01889 272 180**

Fax: **01889 272 181**

email: **sales@intatec.co.uk**

web: **www.intatec.co.uk**