

# inta

---

## Exposed Thermostatic Timed Flow Shower with Adjustable Temperature Control

### NC252CP

## Installation and Maintenance Instructions

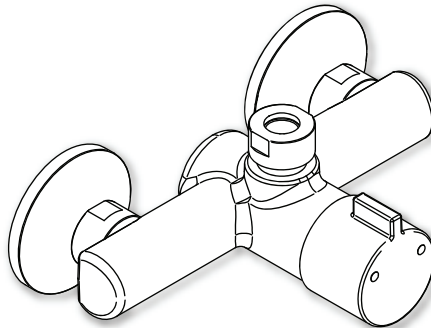

# inta

**Intatec Ltd**

Airfield Industrial Estate

Hixon

Staffordshire

ST18 0PF

In this procedure document we have endeavoured to make the information as accurate as possible.

We cannot accept any responsibility should it be found that in any respect the information is inaccurate or incomplete or becomes so as a result of further developments or otherwise.

Tel: **01889 272 180**

Fax: **01889 272 181**

email: **sales@intatec.co.uk**

web: **www.intatec.co.uk**

## Introduction

This installation guide has been produced for the Timed exposed shower with adjustable temperature control. These instructions cover the installation, operation and maintenance. Please read the enclosed instructions before commencing the installation of this product, please note;

**We recommend that the installation of any Inta product is carried out by an approved installer.**

The installation must be carried out strictly in accordance with the Water Supply (Water Fitting) Regulations 1999 and any local authority regulations.

If in doubt we recommend that you contact WRAS - Water Regulations Advisory Scheme on Tel: 0333 207 9030, your local water authority - details available on the WRAS website or the Chartered Institute of Plumbing and Heating Engineers on Tel: 01708 472 791.

All products **MUST** be re-commissioned to suit site conditions to ensure optimum performance levels of the product are obtained.

It is recommended, especially in hard water areas, that a water softener such as the ActivFlo or ActivFlo lite be fitted to reduce the risk of calcium deposits forming.

## Safety

This thermostatic shower must be installed and commissioned correctly to ensure that water is supplied at a safe temperature to suit the users.

43°C is the maximum mixed water temperature from a shower mixer. The maximum temperature takes account of the allowable tolerances inherent in thermostatic shower mixers and temperature losses.

**It is not a safe washing Temperature for adults or children.**

The British Burns Association recommends 37 to 37.5°C as a comfortable washing temperature for children. In premises covered by the Care Standard Act 2000, the maximum mixed water outlet temperature is 43°C.

## Products

Exposed thermostatic timed flow non-concussive mixer shower with temperature adjustment

NC252CP

## Check Content

Before commencing remove all components from packaging and check each component with the contents list.

Ensure all parts are present, before discarding any packaging. If any parts are missing, do not attempt to install your Inta shower valve until the missing parts have been obtained.

## Components - Shower Valve

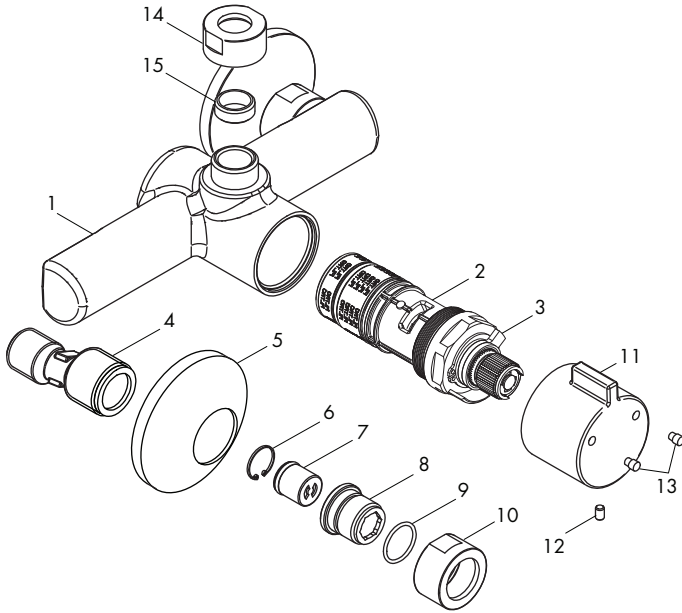

Item	Qty	Component	Item	Qty	Component
1	1	Shower body	9	2	'O' ring
2	1	Thermostatic cartridge	10	2	Swivel nut
3	2	Temperature stop rings	11	1	Control knob
4	2	Off set connector	12	1	Grub screw
5	2	Concealing plate	13	1	Red and blue indices
6	5	Circlip	14	1	Compression nut
7	3	Check valve	15	1	Olive
8	2	Check valve housing			

## Technical Data

This Inta Time Flow shower valve is suitable for installations on all types of plumbing system, including gravity supplies, fully pumped, modulating combination boiler, unvented water heater and unbalanced supplies i.e. Cold Mains & Tank Fed Hot. They are not suitable for non-modulating combination boilers.

Maximum Inlet Pressure (Static):	5 bar
Minimum Operating Pressure (Dynamic):	1 bar
Maximum inlet temperature:	65°C
Minimum inlet temperature:	10°C
Temperature stability:	±2°C
Min. temperature differential to ensure fail-safe between hot and cold supplies:	10°C
Factory set temperature:	41°C
Flow Time @ 1 bar:	15 sec ± 3
Inlet Connections (Body only):	½"
Outlet Connection:	½"

## Unvented Mains Pressure System

The drawing shows a typical installation of a shower mixing valve in conjunction with an unvented hot water system. This type of installation must be carried out in accordance with Part G of the Building Regulations.

Whilst pressures are theoretically equal (balanced) most unvented hot systems have a pressure reducing valve on the incoming cold water prior to the hot water storage vessel. This means that the hot and cold pressures can be significantly different.

Most unvented systems use an inlet manifold located directly after the pressure reducing valve.

It is recommended that the cold supply be taken from one of the outlets of the manifold directly to the shower as an independent supply.

For systems without a manifold unit after the pressure reducing valve and where the cold water supply pressure is significantly higher than the hot supply we recommend that a separate pressure reducing valve is fitted to the cold supply, as close as possible to the shower valve and with no draw off points between it and the shower valve.

Flow regulators are required for installations where a PRV is not fitted to ensure simultaneous demand is accounted for.

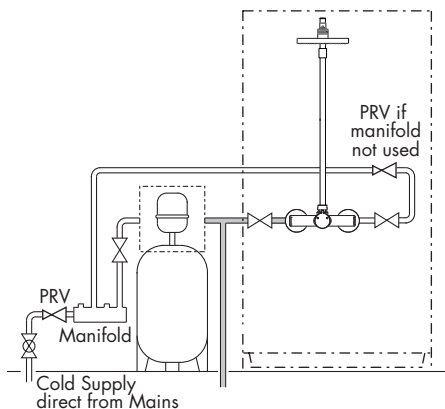

## Pumped Systems

Pumped systems use a booster pump to increase the pressure of the gravity fed water supplies.

These booster pumps are used where the head of water is insufficient to provide a satisfactory shower or where a high performance shower is required.

Please ensure that the performance of the pump is matched to suit the shower.

Follow the instructions for gravity fed installations taking into account the installation requirements of the pump.

Ensure that the hot and cold water storage capacity is sufficient to supply the shower and any other draw off points that may be used simultaneously.

**Most pumps require a minimum head of water to allow the flow switches to operate automatically. Where this is not available a negative head kit may be required to operate the pump.**

Please consult the pump manufacturer's installation requirements.

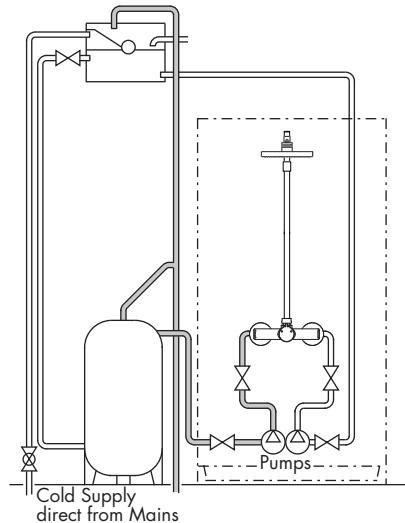

## Modulating Combi Boiler / Instantaneous Gas Water Heater

The drawing shows a typical installation of a shower valve in conjunction with a combination boiler.

Combi boilers will produce a constant flow of water at a temperature within its operating range. However we recommend that the system should supply hot water in excess of 60°C.

The hot water flow rates are dependant upon the type of boiler / heater used and the temperature rise required to heat the cold water to the required temperature.

The cold water flow rates may be much greater as they are generally unrestricted from the mains cold water supply. To ensure relatively balanced flow rates, we recommend that a pressure reducing valve or 6 l/min flow regulator is fitted in the cold water supply pipe.

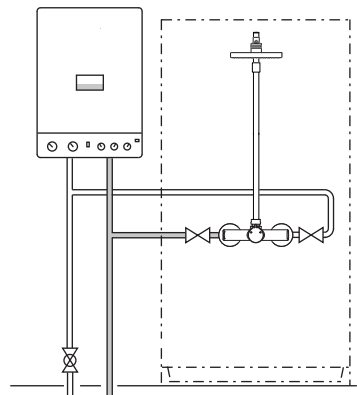

## Gravity System

The drawing shows a typical installation of a shower valve on a gravity supplied system.

Please note the minimum head pressure required to ensure operation of the valve. In accordance with good plumbing practice, we recommend that a totally independent hot and cold water supply be taken to the valve.

The cold water supply must be connected directly to the water cistern. The hot water supply should be connected to the hot water cylinder via an Essex flange or Sussex flange or to the vent or a draw off pipe as close as possible to the top of the cylinder.

For equal tank fed pressures there is no need to fit the flow regulators. This installation is the recommended minimum for gravity supplies. For systems with less than 2 metre head pressure, we recommend that a suitable booster pump is fitted to increase the supply pressure.

### Cold Mains & Gravity Hot Supplies

If the cold supply to the shower is direct from the cold water mains and the hot water supply is gravity fed from the cold water cistern via the hot water cistern you **MUST** fit a pressure reducing valve or a 6 l/min flow regulator.

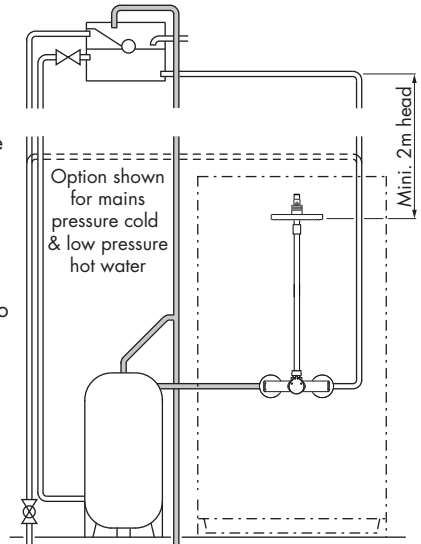

## Dimensions

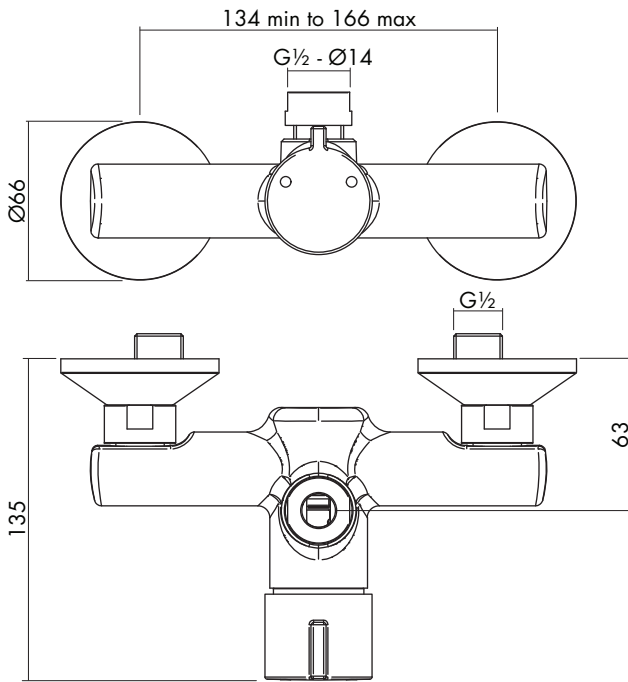

## Site Preparation

**It is important to plan the installation thoroughly to suit site conditions before commencing.**

- Before commencing the installation ensure site conditions are suitable.
- The shower mixing valve is designed for concealed pipework, whether in a solid or studded wall.
- The thickness of wall tiles, plaster or plaster board should all be considered when routing the hot and cold supply pipes.
- The valve requires the offset connectors (4) to have 150 mm centres and as an approximate dimension the shower valve connecting thread and the offset must protrude from the finished wall surface.
- The hole through the wall must be large enough to allow the threaded end of union nut to enter, when connecting the shower valve and finally tightening the union nuts.
- Use a level to ensure the shower valve will be horizontal when installed.
- The supply pipes and offset connectors must be firm and secure to support the shower mixing valve. If not embedded into the wall with plaster the pipes should be fixed securely to the studding or by using a mounting plate elbow (not supplied).
- Angle tap swivel connectors or compression/solder fittings can be used to connect the pipes to the offset connectors (not supplied).
- The whole system should be thoroughly flushed, prior to the connection of the hot and cold water supplies to the shower mixing valve, to remove any debris that may be in the supply pipework.
- Ensure there are no joint leaks before finishing the wall.
- Isolation valves and 'Y' strainers must be fitted in an accessible position to both the hot and cold supplies should the shower valve need to be isolated in the future for servicing.

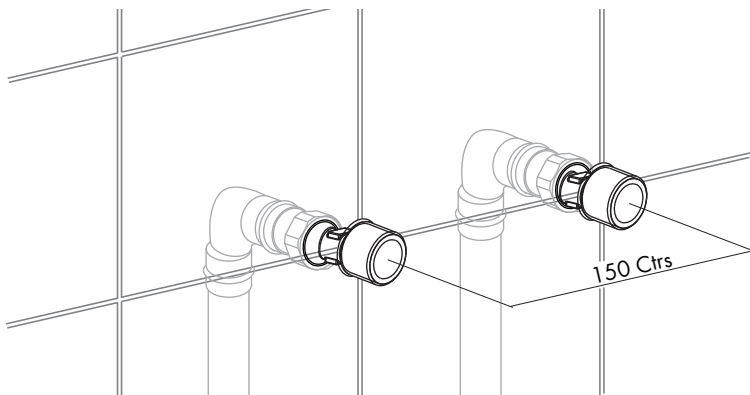



## Installing the Shower Valve

- Place the concealing plates (5), with a bead of mastic on the internal outer edge, over the hot and cold offset connectors and press firmly to the wall.
- Fit the shower valve to the offset connectors and hand tighten the union nuts.
- Using a suitably sized spanner, tighten the union nuts taking care not to damage the finish on the shower valve, do not over tighten.

## Operating

- To operate the shower push the control knob until it contacts a stop and then release, mixed water will then flow for approximately 15 seconds.
- Rotating the control knob anticlockwise progressively closes the hot water port and opens the cold water port until it is fully open when only cold water flows through the shower.
- Rotating the control knob clockwise progressively closes the cold water port and opens the hot water port until there is only hot water flowing through the shower.

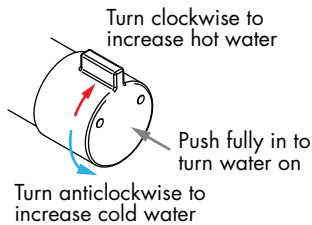

## Aftercare

Inta shower mixing valves have a high quality finish and should be treated with care.

An occasional wipe with a mild washing-up liquid on a soft damp cloth followed by a thorough rinsing is all that is required.

**Do not use** an **abrasive** or **chemical household cleaner** as this may **cause damage**.

## Servicing Instructions

- If the control knob cannot be depressed fully or does not return to its original position within 15 seconds, or the temperature cannot be adjusted easily or water does not flow in a steady stream the shower valve may require servicing.
- Isolate the hot and the cold supplies using the independent isolating valves fitted in the supply pipes.
- Unscrew the grub screw and pull the control knob away from the valve.
- Using a spanner remove the cartridge from the body. Remove any debris that may have collected within the body, ensure the stem rotates freely and can be depressed.
- Do not attempt to dismantle any part of the cartridge, if necessary replace with a new cartridge.
- Check the 'O' rings for any sign of damage and replace if necessary.
- Using washing up liquid as a lubricant, to ease assembly and prevent damage to the 'O' rings, re-assemble the cartridge into the body and tighten.
- Re-assemble the components in the reverse order and turn on the water supplies.
- Check the shower for leaks and correct operation.
- Recalibrate the valve and set to the required water temperature.

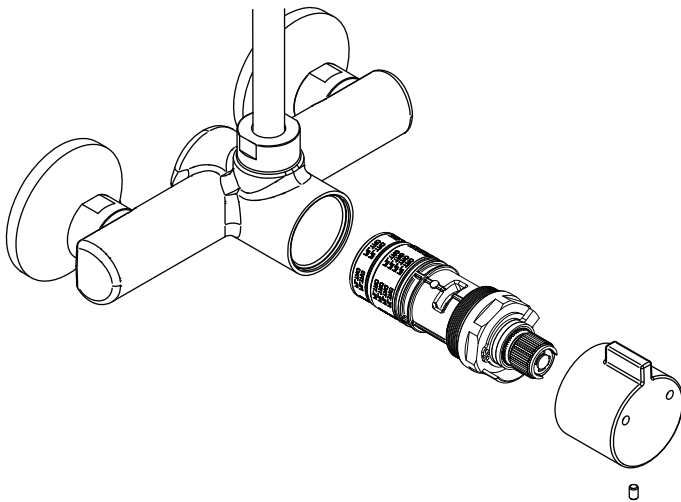

## Calibration

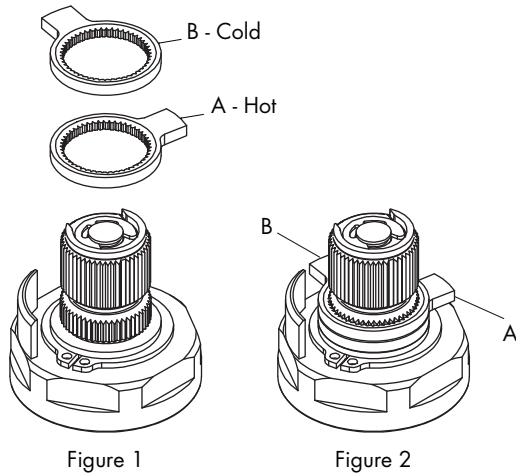

Figure 1

Figure 2

The thermostatic mixer tap has a factory set outlet temperature of 41°C via the security setting. This is based on a balanced supply pressure and a stable hot water inlet temperature of 65°C. However, the calibration point **MUST** be checked and re-set as necessary to suit site conditions. Care must be taken when re-calibrating the tap as **INCORRECT CALIBRATION CAN CAUSE INJURY**.

Unscrew the grub screw (10) and pull the control knob (9) away from the valve.

Remove both temperature stop rings (A & B) from the cartridge as shown in Fig 1.

Temporarily refit the control knob (9).

Using a digital thermometer increase or reduce the mixed water outlet temperature until 41°C is established and stabilised.

Remove the control knob (9) and refit the temperature stop rings (A) onto the splined section of the cartridge at the maximum temperature position.

Temporarily refit the control knob (9) and rotate clockwise until the water flow stops, refit temperature stop ring (B) as shown in Fig 2.

Refit the control knob in the reverse order.

Check calibration temperature.

**PLEASE NOTE THAT ONCE CALIBRATED, THE SECURITY SETTING WILL ONLY BE 41°C UNDER THE SUPPLY CONDITIONS USED FOR CALIBRATION.**

## Spares

A full range of spares are available for this product.

For more information please contact the Technical Department at [technical@intatec.co.uk](mailto:technical@intatec.co.uk) or call on 01889 272199.

**PLEASE NOTE:** Only genuine spares should be used.

## Problem Solving

The following details are supplied for on site queries, should you require any further assistance our Technical Department can be contacted directly on 01889 272199.

Fault	Solution
Showering temperature is not hot enough.	Ensure the hot water supply is at a constant temperature above 60°C. Check for air locks in the pipework.
The water goes cold during showering.	Insufficient stored hot water. When used with a combi boiler confirm that the boiler is still firing. Adjust the boiler to a minimum setting of 65°C which may not necessarily be the best flow rate.
When the water is set at cold, the showering temperature is too hot.	The hot and cold supply connections have been made in reverse.
The maximum showering temperature is too hot or when set to hot water runs to cold.	Check the commissioned maximum temperature of the shower valve. Check the connections to the valve have not been made in reverse.
The flow of water from the shower valve is low.	Check the filters are clean and the supply pressure is above 1.0 bar.
No flow of water	Check that there is hot and cold water flow to the valve. Ensure the check valves are not closed.

**When this Mixer is used in a DO8 Application the following Instructions apply:**

## Introduction

This Inta Thermostatic Mixer Shower has been specifically designed and manufactured to meet the requirements of BS 7942:2011 and NHS D08.

## Technical Specification

Outlet Temperature Adjustment Range	30°C to 50°C
Temperature Stability	±2°C
Maximum Hot Inlet Temperature	85°C
Inlet Temperature Range	55°C to 65°C : Hot Supply 5°C to 20°C : Cold Supply
DO8 Working Pressure Range	1.0 to 5.0 bar : High Pressure
Min Temp Differential (Mix to Hot) for Fail-Safe	10°C
Max. Pressure Inlet Differential	5 : 1
Max. Flow Rate @ 1 bar Differential	1500 l/h (25 l/m)

Operating Pressure Range	High Pressure
Maximum Static Pressure	10 bar
Flow Pressure, Hot and Cold	1 to 5 bar
Hot Supply Temperature	55°C to 65°C
Cold Supply Temperature	5°C to 20°C

## Application

Code	Application	Range
HP-S	Shower	High Pressure

## Installation

IMPORTANT – The following instructions must be read prior to the installation of any Inta thermostatic mixing shower.

The installer should also be aware of his responsibility and duty of care to ensure that all aspects of the installation comply with all current regulations and legislations.

It has been brought to our attention that flushing water systems using certain chemicals may affect the workings of the valve, which may adversely affect its performance.

We recommend that following system flushing with chemicals, mixers are checked for correct operation.

1. It is essential that, before installing a thermostatic mixer, the supply conditions of the system to which the valve is intended to be fitted are checked to confirm compliance with the parameters as quoted within the Technical Specification above and conditions on which the approval is granted i.e. verify supply temperatures, supply pressures, risk assessments etc
2. Consideration must be made for the possibility of multiple/simultaneous demands being made on the supply system whilst the thermostatic mixer is in use, all practical pre-cautions must be made to ensure that the tap is not affected. Failure to make provision within the pipe sizing etc will affect the performance of the shower.
3. The supply system to which the thermostatic mixing tap is to be installed into must be thoroughly flushed and cleaned to remove any debris, which may be accumulated during the installation. Failure to remove any debris will affect the performance and the manufacturer's warranty on the product.
4. Independent filters/check valves and isolation valves must be fitted in conjunction with the shower. In areas subject to hard water, provision must be made to treat the supplies prior to entering any product by fitting a water softener such as an ActivFlo or ActivFlo Lite.
5. The maximum flow rate of the valve will only be achieved when the supply conditions are achieved as quoted, with a flow condition under 1 bar differential pressure.
6. This Inta thermostatic mixer has been designed to be wall mounted. It is essential that access to the shower is not obstructed for future maintenance, that may be required to the shower or associated fittings.
7. The connection of the hot and cold supplies must be in accordance with the instructions shown on pages 3 and 4 i.e. hot water connected to the left hand side of the valve when the handle is facing you.
8. In a situation where one or both of the water supplies are excessive, it is recommended to fit a Pressure Reducing Valve, WRAS approved product, to reduce the pressure(s) to within those stated in the Technical Specification previously stated or a suitable flow regulator.
9. We recommend that Y pattern strainers and full bore isolation valves are installed in conjunction with this product as close as practically possible to the shower.
10. It is essential that this product should not be installed in situations where there is a possibility of the shower being deprived of water or where demands for water are greater than the actual stored supplies.

## Installation

11. To ensure that the performance levels of this Thermostatic Mixer are maintained (in the event of cold water failure) the temperature of the hot water supply at the point of entry to the valve must be a minimum of 10°C above the commissioned mixed water discharge temperature.
12. This Thermostatic Mixer must not be subject to any extreme temperature variations either during the installation or under normal operating condition.

## Commissioning

**IMPORTANT** – The following instructions must be read and understood prior to the commissioning of a Thermostatic Mixer. If under any circumstances there are aspects to the installation/system which do not comply with the specification laid down, the shower **MUST NOT** be put into operation until the system/installation complies with our specification.

1. Ensure that the system is thoroughly cleaned and free from any debris prior to the commissioning of the valve.
2. The commissioning of the temperature must be carried out using a suitably calibrated thermometer – preferably a digital thermometer.
3. In the absence of other temperatures being specified we recommend that the outlet temperatures quoted in table 1 are used, extracted from the “National Health Service – Health Guidance Note – Safe Hot Water and Surface Temperatures”.

**Table 1**

Application	Recommended Set Hot Water Temperature
Shower	41 °C

4. Each tap must be commissioned taking into consideration any fluctuations, which may occur within the system due to simultaneous demands. It is advisable that any outlets which are connected to the same supply as the mixer shower are opened during setting of the mixed water temperature. It is advisable to ensure that the water temperatures are established before any attempt to commission.
5. Once the supply temperatures are stable and the normal operating conditions are established, the valve can be commissioned. We suggest that the following sequence is followed when commissioning the valve:
  - 5.1 Using the lever turn to the maximum hot setting of the tap, the mixed water temperature should be pre-set (see page 3).
  - 5.2 Measure and record the temperature of the hot and cold water connections to the shower.
  - 5.3 Isolate the cold water supply to the valve and monitor the mixed water temperature.

## Commissioning

5.4 Measure and record the maximum mixed water temperature and the final temperature. The final temperature found during the test should not exceed the values quoted in table 2.

**Table 2**

Application	Maximum Set Hot Water Temperature
Shower	43°C

- 5.5 Record all the equipment used during the commissioning.
6. Ensure that the application, to which the shower will be used, is appropriate for the approved designation.
  7. The above information must be recorded and updated on every occasion when any work is carried out on the tap.

## In-service Testing

To ensure that the thermostatic mixer maintains a high level of protection, we advise the following in service testing is followed (the same equipment used to commission the valve initially must be used in the following tasks).

1. After a period of between 6 and 8 weeks after commissioning carry out the following.
  - a) Record the temperature of the hot and cold water supplies.
  - b) Record the temperature of the mixed water at the largest draw off flow rate.
  - c) Record the temperature of the mixed water at the smallest draw off flow rate.
2. If the mixed water temperature has changed significantly from the previous test results (e.g. > 1 k), record the change and before re-setting the mixed water temperature check that:
  - a) All the strainers are clean
  - b) All the check valves are in good working order
  - c) The isolation valves are fully open.
3. If the mixed water temperature is acceptable, carry out the following:
  - a) Record the temperature of the hot and cold water supplies.
  - b) Record the temperature of the mixed water at the largest draw off flow rate.
  - c) Record the temperature of the mixed water at the smallest draw off flow rate.
  - d) Isolate the cold water supply to the mixing valve and monitor the mixed water temperature.
  - e) Record the maximum temperature achieved as a result and the final temperature (the final temperature should not exceed the values quoted in table 2)
  - f) Record the equipment used during these tests.



## In-service Testing

4. If during the test, paragraph 3, the mixed water temperature is greater than the values quoted in table 2 or the maximum temperature exceeds the corresponding values from previous test results by more than 2°C, the tap must be serviced.
5. After a period of between 12 and 15 weeks after commissioning, carry out the sequence of tests as described in 1, 2, 3 and 4 of this section.
6. Dependant upon the results obtained from the first two series of tests; there are a number of possible outcomes.
  - a) If no significant change in the mixed water temperatures (e.g. < 1°C) is recorded between commissioning and step 3e above or between commissioning and 5 of this section, the next in service testing should be carried out at a period of 24 to 28 weeks after initial commissioning.
  - b) If a small change (e.g. 1 - 2°C) in the mixed water temperature is recorded in only one of these periods, necessitating adjustment of the mixed water temperature, then the next in service test can be deferred to 24 to 28 weeks after commissioning.
  - c) If small change (e.g. 1 - 2°C) in the mixed water temperature is recorded in both of these periods, necessitating adjustment of the mixed water temperature, then the next in service test can be deferred to 18 to 21 weeks after commissioning.
  - d) If significant changes (e.g. >2°C) in the mixed water temperature are recorded in both of these periods necessitating service work, then the next in service test should be carried out at 18 - 21 weeks after commissioning.
7. The general principle to be observed after the first two or three in service tests is that the intervals of future test should be set to those which previous tests have shown can be achieved with no more than a small change in mixed water temperature.
8. In all areas periodic maintenance of the valve and associated fittings i.e. strainers, check valves will ensure optimum performance levels are maintained.
9. On the inlet strainers on both the hot and cold water supply inlet can be removed for cleaning.
10. The built in check valves can be accessed in a similar way to the filters to ensure freedom and correct seating.

**Notes:**

**Notes:**

# inta

---

To activate your product warranty please visit  
**[www.intatec.co.uk](http://www.intatec.co.uk)**  
and click on Product Registration

# inta

**Intatec Ltd**

Airfield Industrial Estate  
Hixon  
Staffordshire  
ST18 0PF

Tel: **01889 272 180**

Fax: **01889 272 181**

email: **[sales@intatec.co.uk](mailto:sales@intatec.co.uk)**

web: **[www.intatec.co.uk](http://www.intatec.co.uk)**

E & O.E

© Intatec Ltd 2024

22-05-24