



Product

HPAFPAK1 - Installer Pack 1

Contents

Pre-built installer packs, providing everything you need in one convenient package.

- 2x - 1" F swivel x 1" M flat face extended lever ball valve (HPBV11)
- 1x - 28mm flow balancing valve 5 - 40 L/min with fill & flush (INFBV28)
- 1x - 28mm heat pump filter (IKHPMF28)
- 1x - 28mm auto by-pass valve straight (ABPS28CP)
- 2x - Anti-freeze valves (ZERO28)

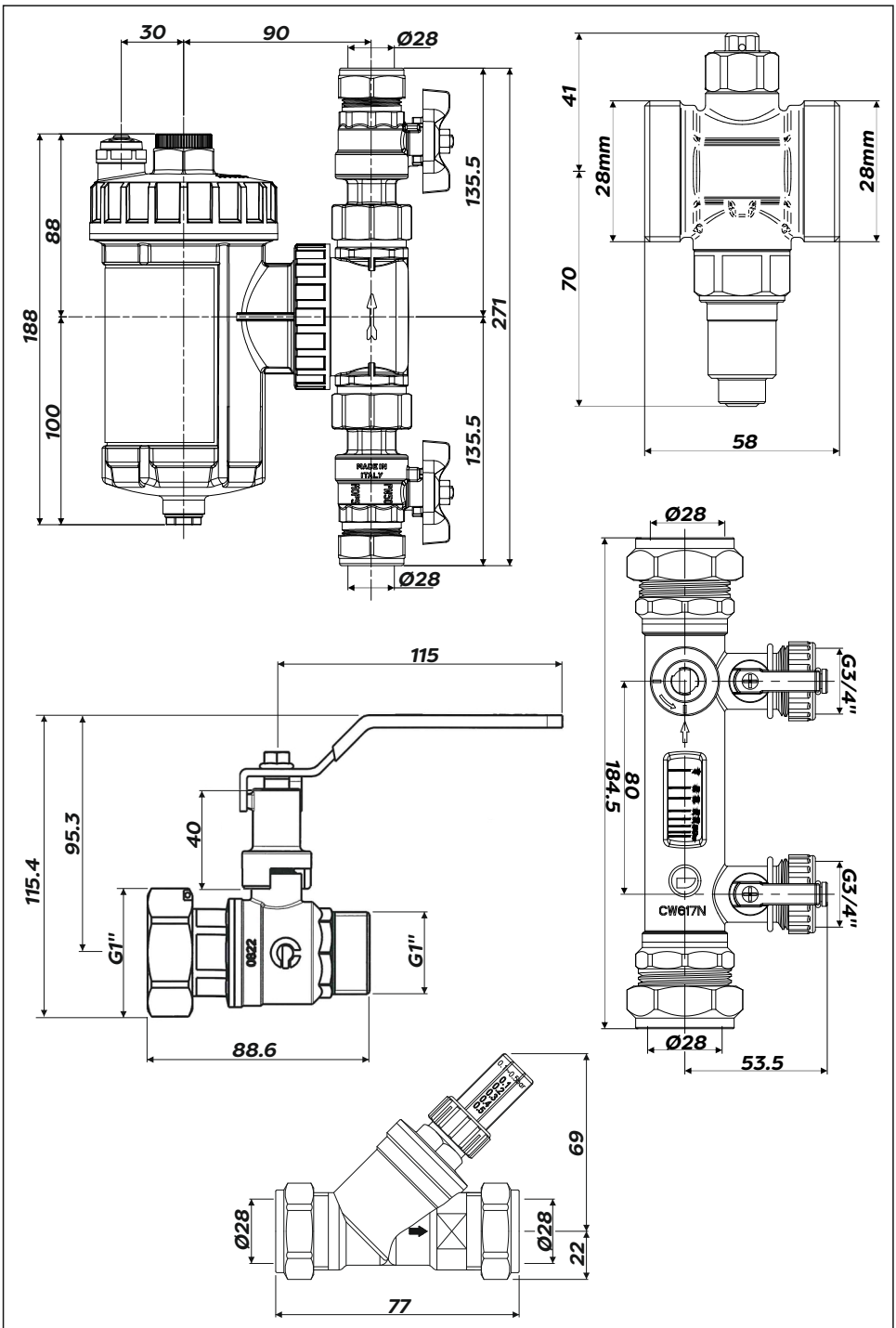

For more information on our heat pump product range please scan:



or visit :
www.intatec.co.uk