



Product

HPAFPAK3 - Installer Pack 3

Contents

Pre-built installer packs, providing everything you need in one convenient package.

- 2x - 1" F swivel x 1" M flat face extended lever ball valve (HPBV114)**
- 1x - 28mm flow balancing valve 5 - 40 L/min with fill & flush (INFBV28)**
- 1x - 28mm heat pump filter (IKHPMF28)**
- 1x - 28mm auto by-pass valve straight (ABPS28CP)**

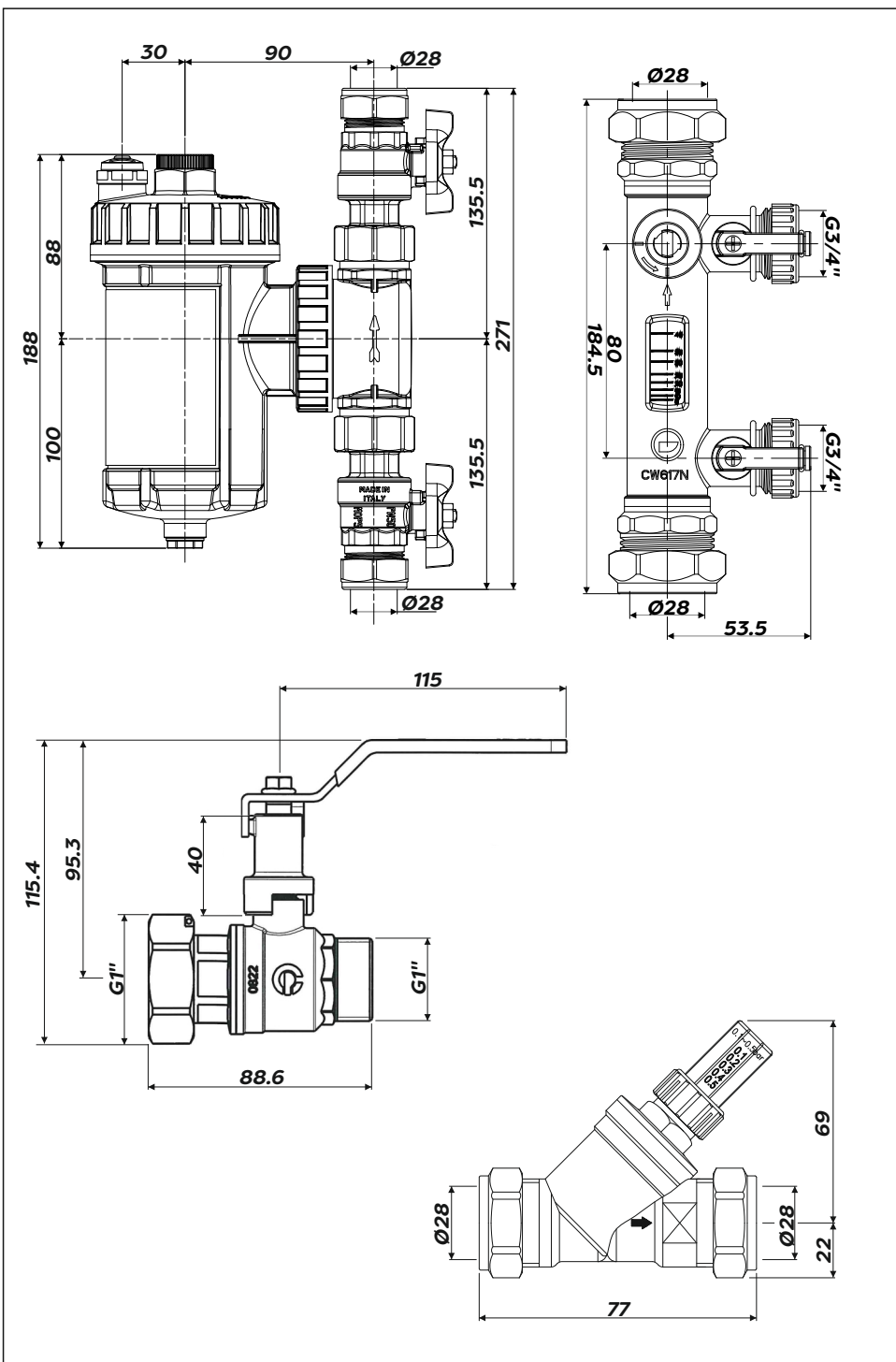

For more information on our heat pump product range please scan:



or visit :
www.intatec.co.uk