

inta

Insulated Buffer Vessel

BUFF25, BUFF50, BUFF80 & BUFF100

Installation and Maintenance Instructions



inta

Intatec Ltd
Airfield Industrial Estate
Hixon
Staffordshire
ST18 0PF

In this procedure document we have endeavoured to make the information as accurate as possible.

We cannot accept any responsibility should it be found that in any respect the information is inaccurate or incomplete or becomes so as a result of further developments or otherwise.

Tel: **01889 272 180**
Fax: **01889 272 181**
email: **sales@intatec.co.uk**
web: **www.intatec.co.uk**

Introduction

This installation document has been prepared for the Inta range of insulated buffer vessels, 25 to 100 litre capacity.

Buffer vessels are designed to store a volume of water to help optimize system efficiency and reduce pump short cycling. Buffer vessels also help to provide hydraulic separation between circuits.

Buffer vessels should be sized according to the requirements of the heat pump system.

We recommend that the installation of any Inta product is carried out by an approved installer.

It is recommended, especially in hard water areas, that a limescale reduction device, such as the ActivFlo or ActivFlo lite, be fitted to reduce the risk of calcium deposits forming.

Products

Description

Buffer vessel - 25 litres, wall mounted with insulation shell
Buffer vessel - 50 litres, floor standing with insulation shell
Buffer vessel - 80 litres, floor standing with insulation shell
Buffer vessel - 100 litres, floor standing with insulation shell

Part Code

BUFF25
BUFF50
BUFF80
BUFF100

Technical Specification

Max. inlet pressure -static:	4 bar
Max. inlet temperature:	95 °C
Fluid type:	water
Glycol mixture:	up to 50%
Outer shell:	steel
Insulation thickness:	41 mm

Dimensions

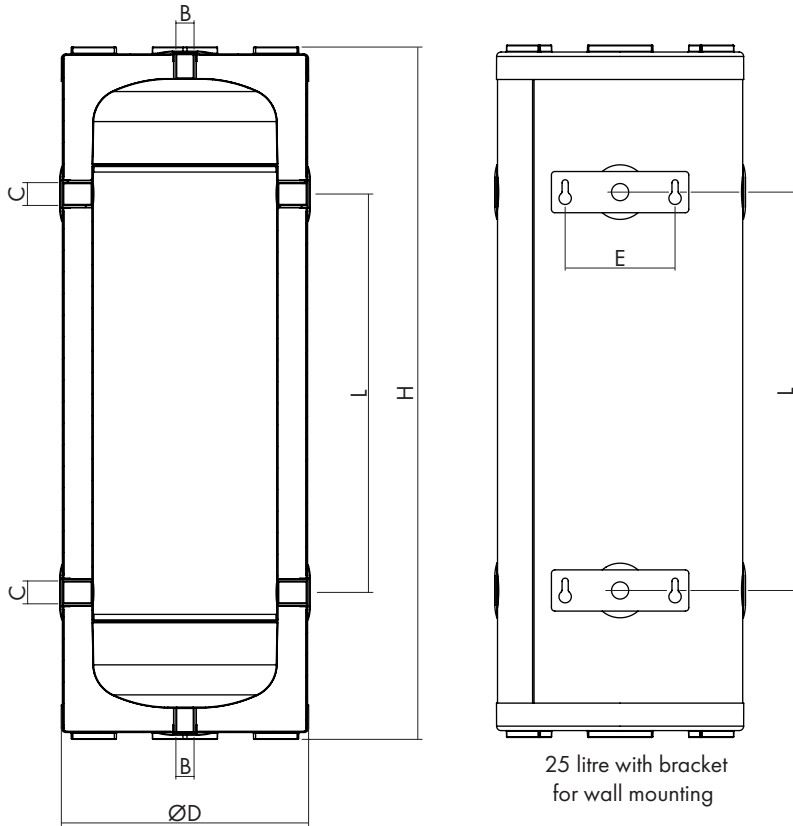

Volume litres	ØD	H	L	E	B	C
25	290	925	480	160	G ³ / ₄	G1
50	360	1008	580	160	G ³ / ₄	G1
80	469	891	365	160	G1 ¹ / ₄	G1 ¹ / ₄
100	469	1071	545	160	G1 ¹ / ₄	G1 ¹ / ₄

Preparation for installation

Access: Ensure safe access to allow the transportation of the buffer vessel to its intended location and adequate lighting is available.

Tools: Ensure the correct tools and consumables are available for the installation before commencing.

Handling and Lifting: Manual handling of large or heavy equipment may present a risk of injury. A full risk assessment should be carried out detailing the appropriate equipment to be used and the method of handling.

Weight: Ensure that the wall or floor is structurally sound to support the filled weight of the buffer vessel and associated fittings and pipework.

Freezing: Provision must be made to protect the buffer vessel against freezing conditions including when not in use and not fully drained.

Storage: The buffer vessel should remain in its packaging until you are about to commence installation. The buffer vessel should be stored vertically in a dry area.

Installation

Ensure that there is sufficient space around the buffer vessel to fit and access the pipe fittings in the 4 side connections.

If wall mounting the 25 litre buffer vessel ensure that the 4 fixing screws are of sufficient size and length to hold the buffer secure.

Stand the buffer vessel vertically on a level floor and connect to 2 flow pipes and 2 return pipes as shown.

The connection where it is shown in the top of the vessel can be used to vent air when filling the system and can be fitted with a manual valve to act as an air vent (not supplied).

Tighten the joints and ensure they are water tight.

When floor standing it is advisable to provide additional support to prevent excessive movement of the buffer vessel.

Commissioning

Before filling check that the expansion vessel in the system is charged to the designated pressure.

Open the main water supply to the buffer vessel.

Flush the system until all the air is expelled, air vents should be fitted at the highest points in the system for this purpose.

The connection at the top of the vessel can be used to aid filling and air venting.

The system should now be full of liquid, check all joints for signs of leakage.

Inhibitor should be added as specified.

The system is now ready for use.

Typical Application

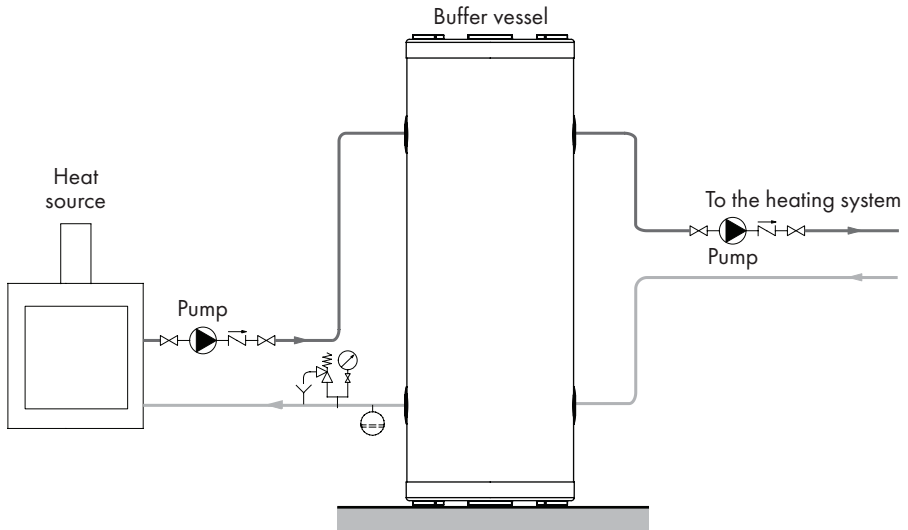

Maintenance

No maintenance as such is required.

Periodically check for signs of leakage from the buffer vessel or from the joints.

Check the outer casing for signs of damage or damage to the insulation.

An occasional wipe to remove dust from the casing is recommended.

If there are signs of leakage or damage the buffer vessel should be replaced.

Notes:

Notes:

inta

Please leave this Manual for the User

To activate your product warranty please visit

www.intatec.co.uk

and click on Product Registration

inta

Intatec Ltd

Airfield Industrial Estate

Hixon

Staffordshire

ST18 0PF

Tel: **01889 272 180**

Fax: **01889 272 181**

email: **sales@intatec.co.uk**

web: **www.intatec.co.uk**

E & O.E