

# inta

---

## ***Concealed Timed Flow Shower with Adjustable Temperature Control***

### **NC145CP**

## ***Installation and Maintenance Instructions***

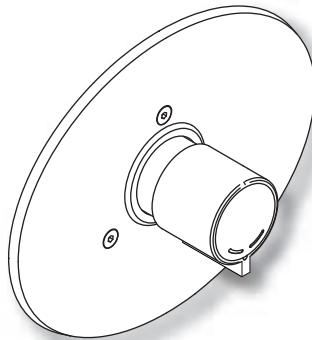

# inta

**Intatec Ltd**

Airfield Industrial Estate

Hixon

Staffordshire

ST18 0PF

In this procedure document we have endeavoured to make the information as accurate as possible.

We cannot accept any responsibility should it be found that in any respect the information is inaccurate or incomplete or becomes so as a result of further developments or otherwise.

Tel: **01889 272 180**

Fax: **01889 272 181**

email: **sales@intatec.co.uk**

web: **www.intatec.co.uk**

## **Introduction**

This installation guide has been produced for the Timed concealed shower with adjustable temperature control. These instructions cover the installation, operation and maintenance. Please read the enclosed instructions before commencing the installation of this product, please note;

***We recommend that the installation of any Inta product is carried out by an approved installer.***

The installation must be carried out strictly in accordance with the Water Supply (Water Fitting) Regulations 1999 and any local authority regulations.

If in doubt we recommend that you contact WRAS - Water Regulations Advisory Scheme on Tel: 0333 207 9030, your local water authority - details available on the WRAS website or the Chartered Institute of Plumbing and Heating Engineers on Tel: 01708 472 791.

All products **MUST** be re-commissioned to suit site conditions to ensure optimum performance levels of the product are obtained.

It is recommended, especially in hard water areas, that a water softener such as the ActivFlo or ActivFlo lite be fitted to reduce the risk of calcium deposits forming.

## **Safety**

This thermostatic shower must be installed and commissioned correctly to ensure that water is supplied at a safe temperature to suit the users.

43°C is the maximum mixed water temperature from a shower mixer. The maximum temperature takes account of the allowable tolerances inherent in thermostatic shower mixers and temperature losses.

***It is not a safe washing Temperature for adults or children.***

The British Burns Association recommends 37 to 37.5°C as a comfortable washing temperature for children. In premises covered by the Care Standard Act 2000, the maximum mixed water outlet temperature is 43°C.

## **Products**

Timed Flow Shower with Adjustable Temperature Control - Concealed

NC145CP

## **Check Content**

Before commencing remove all components from packaging and check each component with the contents list.

Ensure all parts are present, before discarding any packaging. If any parts are missing, do not attempt to install your Inta shower valve until the missing parts have been obtained.

## Components - Shower Valve

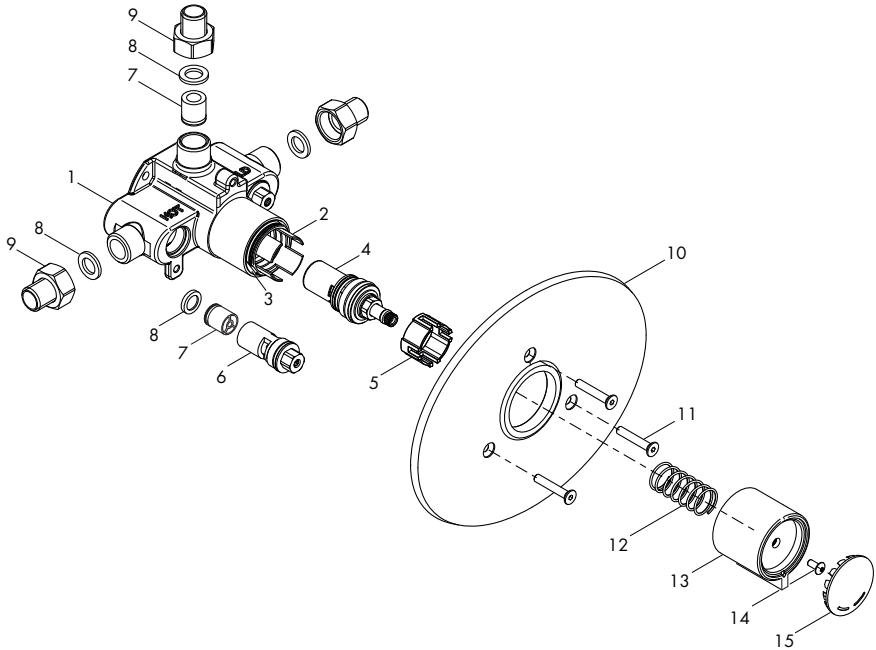

Item	Qty	Component	Item	Qty	Component
1	1	Shower body	9	3	Tailpiece and compression nut
2	1	Outer cartridge sleeve	10	1	Concealing plate
3	1	Outer cartridge retaining ring	11	3	Concealing plate retaining screw
4	1	Thermostatic cartridge	12	1	Return spring
5	1	Plastic centraliser	13	1	Control knob
6	2	Check valve holder	14	1	Retaining screw
7	2	Check valve	15	1	Cover
8	5	Filter sealing washers			

## Technical Data

This Inta Time Flow shower valve is suitable for installations on all types of plumbing system, including gravity supplies, fully pumped, modulating combination boiler, unvented water heater and unbalanced supplies i.e. Cold Mains & Tank Fed Hot. They are not suitable for non-modulating combination boilers.

Max Inlet Pressure (Static)	6 bar
Max Inlet Pressure (Range)	2 to 4 bar
Min Operating Pressure (Dynamic)	1 bar
Flow Time	15 sec ± 5
Temperature range:	5 to 65°C
Inlet Connections (Body only)	½" with ⅜" reducer
Outlet Connection	½" with ⅜" reducer

## Dimensions

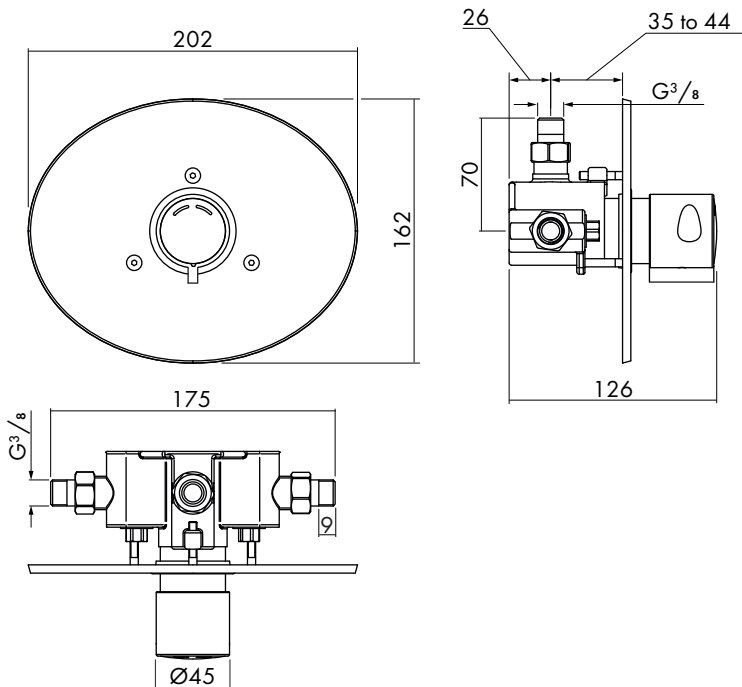

---

## **Site Preparation**

***It is important to plan the installation thoroughly to suit site conditions before commencing.***

- Before commencing the installation ensure site conditions are suitable.
- The shower mixing valve is designed for concealed pipework, whether in a solid or studded wall.
- Site conditions will determine how the shower valve and outlet elbow (not supplied) will be installed.
- The thickness of wall tiles, plaster or plaster board should all be considered when positioning the shower valve and routing the hot and cold supply pipes.
- The shower valve must protrude sufficiently from the finished tiled surface to allow the concealing plate and control knobs to be fitted.
- Ensure the shower valve will be vertical when installed.
- The supply pipes can come from below, above, the side or through the wall.
- The shower valve must be fixed securely to the wall or studding using screws in the 2 mounting holes. Do not embed into a solid wall or tile over the valve as this will prevent the shower valve from being removed should future maintenance be required.
- The concealing plate is large enough to cover the valve and union fittings.
- The whole system should be thoroughly flushed, prior to the connection of the hot and cold water supplies to the shower valve, to remove any debris that may be in the supply pipework.
- Ensure there are no joint leaks before finishing the wall.
- Isolation valves must be fitted in an accessible position to both the hot and cold supplies should the valve need to be isolated in the future for servicing.

## **Installation - Shower Valve**

### **Solid wall**

- Create a large enough cavity for the shower valve and chase the wall for the two supply pipes and a route from the outlet of the shower valve to the outlet elbow (not supplied).
- Fix the shower valve into the cavity using the 2 fixing holes ensuring the valve is horizontally in line.
- Ensure that the outer collar of the body and thermostatic cartridge protrude sufficiently from the finished wall surface to allow the concealing plate and control knobs to be fitted, see dimension drawing.

## **Cavity wall**

- The shower valve must be fixed securely to the structural members of the stud wall and/or an additional member may need to be included where the shower valve will be located.
- If there is access from the adjacent room into the cavity, the surface of the shower room wall can be finished with most of the tiling completed. Allow a sufficiently sized hole should the shower valve need to be removed for future maintenance. The concealing plate is sufficiently large enough to cover the shower valve.
- Fix the shower valve to the structural member using 2 screws of sufficient length and tighten to hold secure.
- Ensure that the outer collar of the body and thermostatic cartridge protrude sufficiently from the finished wall surface to allow the concealing plate and control knobs to be fitted, see dimension drawing.
- An additional holes need to be made for the outlet elbow. The tiling around this hole needs to be completed to allow the these components to be fitted.

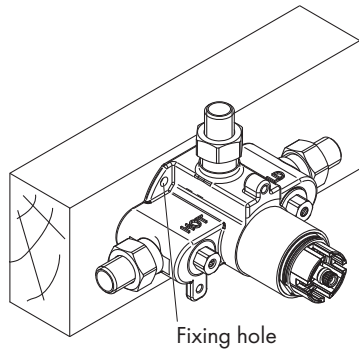

## **Installation - Concealing Plate**

- Fit the outlet elbow and connect to the top outlet of the shower valve.
- Turn on the water supplies and test all joints for leakage before finishing the wall. Any leaking joints must be rectified before proceeding further.

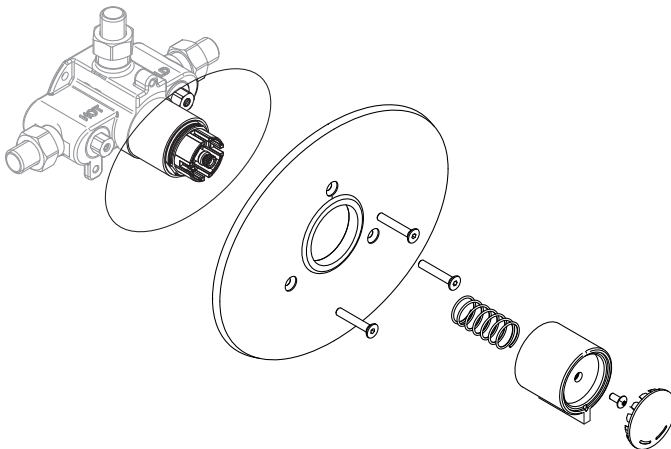

## **Installation - Concealing Plate**

- Place the concealing plate with a bead of mastic on the back, adjacent to the outer edge, over the shower valves and press firmly to the wall.
- Secure the concealing plate to the shower valve and wall using the 3 screws provided.
- Fit the return spring and control knob and secure with the screw and fit the cover.

## **Operating**

- To operate the shower push the control knob until it contacts a stop and then release, mixed water will then flow for approximately 15 seconds.
- Rotating the control knob anticlockwise progressively closes the hot water port and opens the cold water port until it is fully open when only cold flows through the shower.
- Rotating the control knob clockwise progressively closes the cold water port and opens the hot water port until there is only hot water flowing through the shower

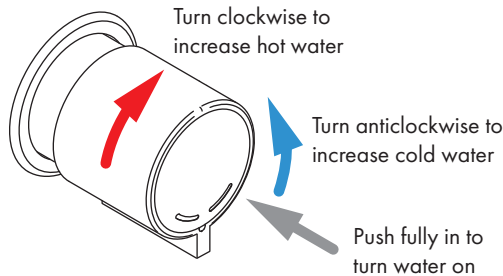

## **Isolating the Inlet Ports**

The hot and cold water supplies can be isolated using the screw driver slot in the check valve holder and rotating in a clockwise direction.

This manually isolates the check valve in the closed position preventing water flow into the main body of the shower.

To restore the water supply rotate in an anticlockwise direction

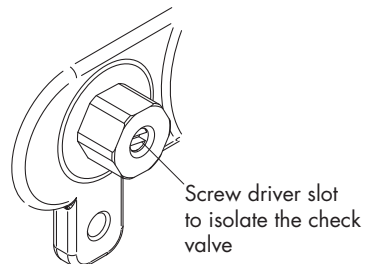

## Aftercare

Inta shower mixing valves have a high quality finish and should be treated with care.

An occasional wipe with a mild washing-up liquid on a soft damp cloth followed by a thorough rinsing is all that is required.

**Do not use** an **abrasive** or **chemical household cleaner** as this may **cause damage**.

## Servicing Instructions

- If the control knob cannot be depressed fully or does not return to its original position within 15 seconds, or the temperature cannot be adjusted easily or water does not flow in a steady stream the shower valve may require servicing.
- Isolate the hot and the cold supplies using the screw driver slot isolation valves. If independent isolating valves are fitted in the supply pipe it is recommended to isolate these valves as well.
- Remove the cover, unscrew the retaining screw and carefully remove the control knob ensuring the return spring does not escape and cause injury.
- Remove the plastic centraliser by pulling out of the outer collar of the body.
- Using a spanner remove the cartridge from the body. Remove any debris that may have collected within the body, ensure the stem rotates freely and can be depressed.
- Do not attempt to dismantle any part of the cartridge, if necessary replace with a new cartridge.
- Check the 'O' rings and return spring for any signs of damage and replace if necessary.
- Using washing up liquid as a lubricant, to ease assembly and prevent damage to the 'O' rings, re-assemble the cartridge into the body and tighten.
- Re-assemble the other components in the reverse order and turn on the water supplies.
- Check the shower for leaks and correct operation

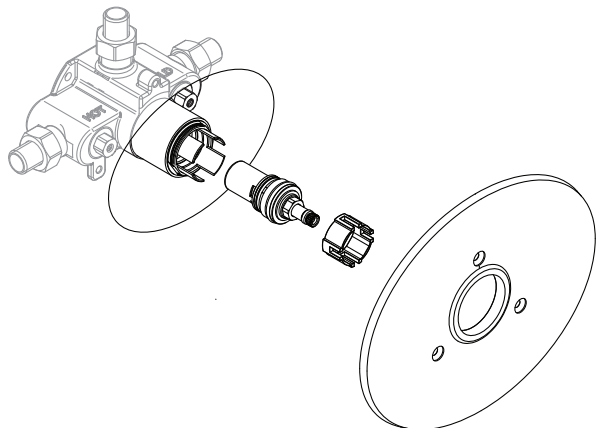



## Spares

A full range of spares are available for this product.

**PLEASE NOTE:** Only genuine spares should be used.

## Problem Solving

The following details are supplied for on site queries, should you require any further assistance our Technical Department can be contacted directly on 01889 272199.

<b>Fault</b>	<b>Solution</b>
Showering temperature is not hot enough.	Ensure the hot water supply is at a constant temperature above 60°C. Check for air locks in the pipework.
The water goes cold during showering.	Insufficient stored hot water. When used with a combi boiler confirm that the boiler is still firing. Adjust the boiler to a minimum setting of 65°C which may not necessarily be the best flow rate.
When the water is set at cold, the showering temperature is too hot.	The hot and cold supply connections have been made in reverse.
The maximum showering temperature is too hot or when set to hot water runs to cold.	Pressure may be unbalanced Check the connections to the valve have not been made in reverse.
The flow of water from the shower valve is low.	Check the filters are clean and the supply pressure is above 1.0 bar.
No flow of water	Check that there is hot and cold water flow to the valve. Ensure the check valves are not closed.





# inta

---

To activate your product warranty please visit  
**[www.intatec.co.uk](http://www.intatec.co.uk)**  
and click on Product Registration

# inta

**Intatec Ltd**

Airfield Industrial Estate  
Hixon  
Staffordshire  
ST18 0PF

Tel: **01889 272 180**

Fax: **01889 272 181**

email: **[sales@intatec.co.uk](mailto:sales@intatec.co.uk)**

web: **[www.intatec.co.uk](http://www.intatec.co.uk)**

E & O.E

© Intatec Ltd 2023

21-07-23